

OVER 70 YEARS OF QUALITY AND SERVICE

Royal

PINS

PUNCHES

PERFORATORS

and
SPECIALIZED
COMPONENTS
for DIES
and MOLDS



PRECISION



QUALITY



PERFORMANCE



Royal

ESTABLISHED "1946"



Precision Crafted Pins, Punches, Perforators, and Specialized Components for Dies and Molds



Our modern plant in Warren, Rhode Island, and our large investment in highly specialized equipment, ensures that all our customers receive the highest quality Punches, Pins, and Perforators available in the world today

THE ROYAL FAMILY of PUNCHES and PINS

Royal Diversified Products Inc., was founded in 1946 and was one of the pioneers of the economical 60 degree bevel headed punch.



Royal offers a wide variety of Pins, Punches, and Perforators for use in the Stamping, Molding, and related industries.

MATERIALS & COATINGS

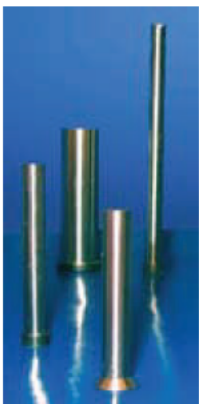

Royal uses only the highest quality steels for pins and punches. A variety of coatings are available including: Ion Nitriding, TiN, Black Oxide, and Tungsten DiSulfide (WS2) coating. All of these and other coatings offered per quotation.

EXPERT HEAT TREATMENT



Along with traditional methods, ROYAL'S in-house heat treatment department utilizes computer regulated vacuum furnaces pre-programmed with a proprietary heat treating process.

This results in M-2 High Speed Steel with remarkable tensile strength *combined* with high hardness. This strength and flexibility is found **ONLY** in Royal Pins. (See Photo: on the right)



ROYAL SERVICE

Royal ships more punches and perforators the same day, from stock, than anyone else. In most cases customer orders received before 3pm E.S.T., are shipped the same day.

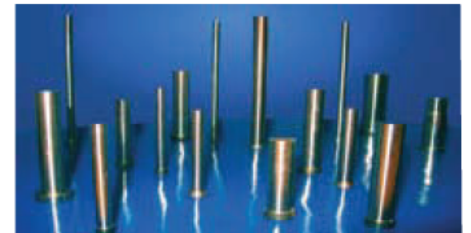

PREMIUM/EXPEDITED SERVICES

When you order non-standard or special pins, we make every effort to get them to you as soon as we can. However, ROYAL recognizes that sometimes you need to receive delivery earlier than our estimated shipment date. When this is the case, please call us. Usually we can offer other options to speed up delivery.



CUSTOM MODIFICATIONS



The modifications shown below are only those most frequently requested and do not represent the limit of our capabilities with regards to size ranges and tolerances. Also, please refer to the worksheet templates provided on pages 25-27.

Modification	Type	Description	Tolerances	How To Order: Examples
	ML	REDUCED OVERALL LENGTH Stock removal from front-end. Minimum length .500". Lengths under .500" per special quote only.	+ .015"/-.000" [+0.5/-0.0]	SQD .230 ML=1.063 HSS B-1 .030 ML=1.750 RQA .056 ML=1.500
	CL	PRECISION OVERALL LENGTH Same as above except closer tolerance held.	+/- .001" [+/-0.03]	RQB .175 CL=2.157 RCX-9 CL=5.312 PT-5-1/2 CL=4.093
	MT	REDUCED HEAD THICKNESS Shorter head than standard. Stock removal from back of head Shortens overall length	+ .010"/-.000" [+0.3/-0.0]	SQD .157 X2-1/2 TS, MT=.094 RC-17 L-3, MT=.156
	CT	PRECISION HEAD THICKNESS Same as above except closer tolerance held.	+/- .001" [+/-0.03]	SQD .204 X 2 1/2 HSS, CT=.118 RQB .090 X 2-1/2, CT= .090 RQA .130 X 6, CT=.083
	MH	REDUCED HEAD DIAMETER Head diameter smaller than standard. Minimum head diameter equals "D". Grinding head diameter on RQA does not change head thickness.	+ .000"/-.010" [+0.0/-0.3]	RQB .240 X 4, MH=.280 SQD .370 X 2-1/2 HSS, MH=.437
	PH	PRECISION HEAD DIAMETER Same as above except closer tolerance held.	+/- .001" [+/-0.03]	PT-11 L-6, PH=.250
	PS	PUNCH STEP "B" = .750" Max. Specify "B" or "SBR" and "P" including tolerance	B +.06" -.00" SBR +.06" -.00"	RQB-PS .125 X 2-1/2, P=.093 +.0003/-0, B=.500 CPB-PS-12 X 2-1/2, P=.109+.0005/-0, B=.625 PPB-PS 37 X 3, P=.290 +.0002/-0, SBR=.437 AB-20-PS .312 X 3-1/2, P=.255 +.0003/-0, B=.500
	CS	CORE PIN STEP - STRAIGHT "B" = .750" Max. Should be ordered in conjunction with "CL" modification and "CT" if required. Specify "B", "P", "CL" and "CT" if required.	B +/- .001" CL +/- .001" CT +/- .001" P1 +.001"/-0 P - Specify	RQB-CS .067, CL=.940, B=.210, P=.050 RCX-13-CS, CL=2.590, B=.700, P=.157 PT-10-CS, CL=3.750, B=.730, P=.133
	CSD	CORE PIN STEP - DRAFT B=.750" max. Includes custom modifications "CL" and "CT" if required. Specify "B", "P1", "P2", "CL" and "CT" if required.	B +/- .001" CL +/- .001" CT +/- .001" P1 +.001"/-0 P2 +.001"/-0	RCX-19 -CSD, CL=2.187, B=.431, P1=.255, P2=.263 RQB-CSD .236, CL=.870, B= .575, P1=.197, P2= .207, CT = .125
	PN	PILOT NOSE Pilot nose is included in the overall length. Pilot is manufactured with .119 radius.	Standard	SQF-PN .250 X 2-1/2 HSS B-15-PN .238 X 3 RQA-PN .136 X 2-1/2
	SR	SPHERICAL RADIUS Radius is half the diameter. Also specify "ML" or "CL" AND "CT" if required.	Standard	RQB-SR .060 X 2-1/2 AB-7-SR .125 X 2 RCX-11-SR L-3
Special Hardness	HD	ANNEALED HEADS Induction annealing of heads to a lower Rockwell hardness for improved strength.		RQB-HD .125 x 2-1/2
		SPECIAL HARDNESS When a hardness other than catalog standard is required.	Specify hardness range required.	SQD .187 x 2-1/2 TS, Rc 45-50
Coatings	TiN	TITANIUM NITRIDE COATING PVD wear resistant thin film coating. TiN is an excellent coating for wear part applications demanding resistance to abrasive and adhesive wear. Typical coating thickness is .00005" to 00010" per side.	Diameter tolerances are before coating only. We cannot guarantee tolerance after coating.	RQB .075 X 4 TiN
	WS2	PERMANENT DRY-LUBE TREATMENT A Tungsten Disulfide coating that provides a thin barrier between opposing metal surfaces and prevents metal to metal contact to improve lubricity. Applied at room temperature and unaffected by the heat of the molding process, it will extend the life of the pins while providing fail safe protection by eliminating galling and seizing. Tungsten disulfide does not migrate to the molded surface. Typical coating thickness is .000020" per side.	Diameter tolerances are before coating only. We cannot guarantee tolerance after coating.	RX-25 L-10 (WS2) PT-5-2 L-6 (WS2)

[] DENOTES TOLERANCES HELD ON METRIC PARTS



PERFORATORS/CORE PIN BLANKS

M-2 HIGH SPEED STEEL, 60-63 RC

PRECISION FORM-GROUND

DIAMETERS IN .001" OR .0001" INCREMENTS

The following fractional diameters are included in the .001 increment price tables below 1/32 3/64 1/16 5/64 3/32 7/64 1/8 9/64 5/32 3/16 7/32 1/4 9/32 5/16 & 3/8.

HOW TO ORDER: EXAMPLES				
Qty.	Type	Dia.	X	Length
25	RQA	.1875	X	4
50	RQA	.197	X	2-1/2

D DIAMETER .001" INCREMENTS	NET PRICE EACH PER QUANTITY (US \$)				
	L - LENGTH				
	2"				
	50-99	25-49	10-24	5-9	1-4
.010 - .014	4.80	5.26	5.91	8.04	9.63
.015 - .019	4.00	4.40	4.90	6.69	8.04
.020 - .029	3.20	3.51	3.93	5.40	6.46

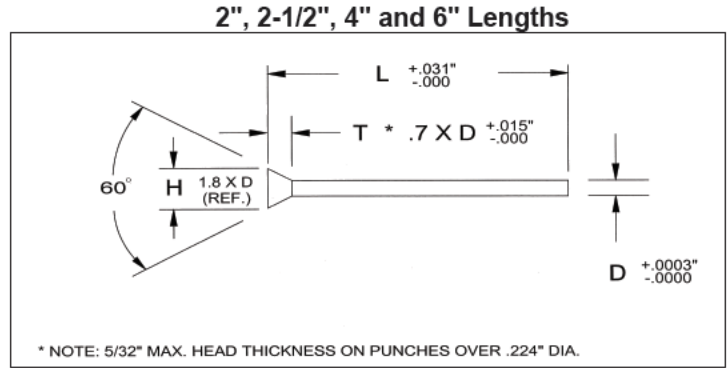

Q = Price Per Quotation

D DIAMETER .001" INCREMENTS	NET PRICE EACH PER QUANTITY (US\$)														
	L - LENGTH														
	2-1/2"					4"					6"				
	50-99	25-49	10-24	5-9	1-4	50-99	25-49	10-24	5-9	1-4	50-99	25-49	10-24	5-9	1-4
.030 - .055	2.54	2.79	3.16	4.29	5.17	Q	Q	Q	Q	Q	Q	Q	Q	Q	Q
.056 - .087	2.74	3.00	3.37	4.57	5.50	5.92	6.50	7.29	11.48	18.50	10.74	11.74	13.18	17.89	24.93
.088 - .131	3.06	3.34	3.76	5.14	6.15	5.46	5.98	6.69	10.83	17.85	10.26	11.25	12.60	17.25	24.28
.132 - .179	3.20	3.51	3.93	5.40	6.46	5.61	6.13	6.92	11.05	18.09	10.42	11.40	12.79	17.47	24.50
.180 - .225	3.70	4.05	4.53	6.18	7.40	6.12	6.68	7.45	11.66	18.68	10.88	11.92	13.39	18.12	25.15
.226 - .250	4.18	4.57	5.12	6.98	8.38	6.55	7.20	8.06	12.30	19.34	11.36	12.46	13.95	18.75	25.76
.251 - .336	4.68	5.10	5.73	7.81	9.36	7.06	7.70	8.64	12.93	19.96	11.88	12.98	14.59	19.42	26.46
.337 - .375	5.07	5.53	6.20	8.46	10.15	7.46	8.16	9.15	13.50	20.52	12.25	13.44	15.06	19.94	26.97
	STANDARD					NON-STANDARD									

DIAMETERS IN .0001" INCREMENTS MADE TO ORDER	SETUP CHARGE - ADD TO STANDARD PRICE		
	2-1/2"	4"	6"
	\$35.00		\$65.00

QUANTITY DISCOUNTS	
Based on one size, one shipment and one destination	
100 Pcs.....50 Pc. Price Less 7%	Over 300 Pieces..... Call For Pricing

Please see PAGE 1 for a complete list of modifications that are available for any of the ROYAL Family Of Pins and Punches

RQB TYPE



PERFORATORS/CORE PIN BLANKS

M-2 HIGH SPEED STEEL, 60-63 RC

PRECISION FORM-GROUND .001" OR .0001" INCREMENTS



Including the popular fraction sizes:

1/32, 3/64, 1/16, 5/64, 3/32,
7/64, 1/8, 9/64, 5/32, 3/16,
7/32, 1/4, 9/32, 5/16, & 3/8.

Q= Price Per Quotation

D DIAMETER .001" INCREMENTS	H HEAD DIA.	T HEAD THICK.	NET PRICE EACH PER QUANTITY (US \$)				
			2"				
			50-99	25-49	12-24	5-11	1-4
.010 - .014	1/32	1/16	4.89	5.34	6.02	8.19	9.84
.015 - .019	1/32	1/16	4.09	4.46	5.01	6.84	8.19
.020 - .029	3/64	1/16	3.27	3.58	4.03	5.49	6.22

D DIAMETER .001" INCREMENTS	H HEAD DIA.	T HEAD THICK.	NET PRICE EACH PER QUANTITY (US \$)					NET PRICE EACH PER QUANTITY (US \$)									
			L - LENGTH					L - LENGTH									
			2-1/2"					3"									
			50-99	25-49	12-24	5-11	1-4	50-99	25-49	12-24	5-11	1-4					
.030 - .036	1/16	1/16	2.62	2.85	3.20	4.39	5.29	Q	Q	Q	Q	Q					
.037-.046	5/64	1/16						2.80	3.08	3.44	4.68	5.61	3.24	3.51	3.96	5.42	6.50
.0469-.055	3/32	3/32											3.08	3.42	3.82	5.20	6.25
.056-.064	7/64	3/32	3.27	3.58	4.03	5.49	6.58										
.065-.0781	1/8	3/32						3.78	4.12	4.62	6.31	7.54					
.079-.087	9/64	3/32											4.34	4.75	5.32	7.26	8.70
.088-.099	5/32	3/32	4.34	4.75	5.32	7.26	8.70										
.100-.120	11/64	3/32						4.87	5.31	5.95	8.12	9.72					
.121-.131	3/16	1/8											5.28	5.77	6.46	8.80	10.56
.132-.147	13/64	1/8	6.15	6.72	7.54	10.29	12.34										
.148-.163	7/32	1/8						6.97	7.62	8.55	11.66	14.00					
.164-.179	15/64	1/8											7.81	8.54	9.58	13.09	15.69
.180-.194	1/4	1/8	STANDARD														
.195-.210	17/64	1/8															
.211-.225	9/32	1/8	STANDARD					NON-STANDARD									
.226-.241	19/64	1/8															
.242-.250	5/16	3/16	STANDARD					NON-STANDARD									
.251-.256	5/16	3/16															
.257-.272	21/64	3/16	STANDARD					NON-STANDARD									
.273-.288	11/32	3/16															
.289-.304	23/64	3/16	STANDARD					NON-STANDARD									
.305-.320	3/8	3/16															
.321-.336	25/64	3/16	STANDARD					NON-STANDARD									
.337-.352	13/32	3/16															
.353-.368	27/64	3/16	STANDARD					NON-STANDARD									
.369-.380	7/16	3/16															
.381-.396	29/64	3/16	STANDARD					NON-STANDARD									
.397-.411	15/32	3/16															
.412-.427	31/64	3/16	STANDARD					NON-STANDARD									
.428-.443	1/2	3/16															
.444-.458	33/64	3/16	STANDARD					NON-STANDARD									
.459-.474	17/32	3/16															
.475-.489	35/64	3/16	STANDARD					NON-STANDARD									
.490-.505	9/16	3/16															

Length and Diameter Modifications on the above NON-STANDARD pins are available PER QUOTATION

	STANDARD		NON-STANDARD	
DIAMETERS IN .0001" INCREMENTS MADE TO ORDER. .0300 DIA. AND UP ADD THE FOLLOWING SET UP CHARGE TO BASE PRICE	2" PER QUOTE	\$40.00 (2-1/2" only)		
OPTIONAL T = 3/16" MADE TO ORDER ADD THE FOLLOWING NO SET UP CHARGE TO BASE PRICE	2" PER QUOTE	\$30.00 (2-1/2" only)		

QUANTITY DISCOUNTS
Based on one size, one shipment and one destination
100 pieces50 pc. price - 7% Over 300 pieces Call for pricing



2", 2-1/2", 3", 4", 6", and 8" Lengths

HOW TO ORDER EXAMPLE				
Qty.	Type	Dia.	X	Length
50	RQB	.128	X	2-1/2

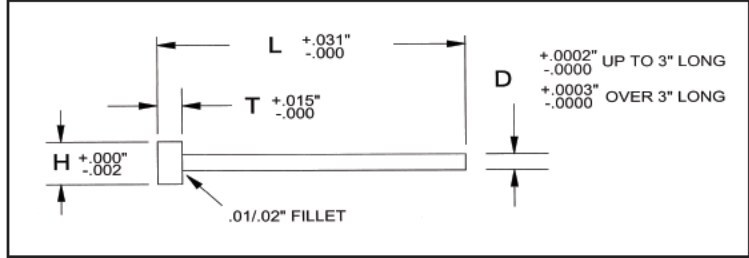

Q= Price Per Quotation

NET PRICE EACH PER QUANTITY (US \$)														
L - LENGTH														
4"					6"					8"				
50-99	25-49	12-24	5-11	1-4	50-99	25-49	12-24	5-11	1-4	50-99	25-49	12-24	5-11	1-4
Q	Q	Q	Q	Q	Q	Q	Q	Q	Q	Q	Q	Q	Q	Q
6.03	6.63	7.42	11.70	18.85	11.14	12.22	13.68	18.57	25.88	Q	Q	Q	Q	Q
5.58	6.09	6.85	11.05	18.20	10.66	11.68	13.06	17.91	25.22	15.78	17.29	19.40	30.37	48.79
5.84	6.39	7.17	11.47	18.76	10.82	11.84	13.29	18.18	25.46	15.94	17.47	19.58	30.56	48.99
6.36	6.93	7.76	12.12	19.41	11.30	12.37	13.89	18.84	26.10	16.46	18.02	20.19	31.23	49.65
6.90	7.54	8.46	12.93	20.28	11.90	13.04	14.62	19.65	27.03	16.82	18.40	20.65	31.65	49.88
6.90	7.54	8.46	12.93	20.28	THIS SIZE RANGE IS AVAILABLE PER QUOTATION									
7.42	8.08	9.07	13.58	20.94										
7.81	8.54	9.58	14.14	21.51										
9.49	10.38	11.64	16.40	23.74										
11.17	12.24	13.69	18.64	26.01										
12.02	13.15	14.74	19.76	27.13										
NON-STANDARD														
Length and Diameter Modifications on the NON-STANDARD pins (above) are AVAILABLE PER QUOTATION														

Please see PAGE 1 for a complete list of modifications that are available for any of the ROYAL Family of Pins and Punches



QUILL PUNCHES/ CORE PIN BLANKS

MATERIAL: TOOL STEEL (TS)

OHTS, 58-60 RC, HEADS DRAWN OVER 1/16 DIA.

HIGH SPEED STEEL (HSS)

M-2, 60-63 RC

PRECISION FORM - GROUND

SQF TYPE FRACTIONAL DIAMETERS

SQD TYPE: DECIMAL DIAMETERS .030" THROUGH .374" IN .001" INCREMENTS. DIAMETERS IN .0001" INCREMENTS CAN BE MADE TO ORDER. ADD \$35.00 SET-UP CHARGE.

HOW TO ORDER EXAMPLES					
Qty.	Type	Dia.	X	Length	Steel
50	SQF	.0937	X	2-1/2	TS
100	SQD	.136	X	2-1/2	HSS

2-1/2" Lengths

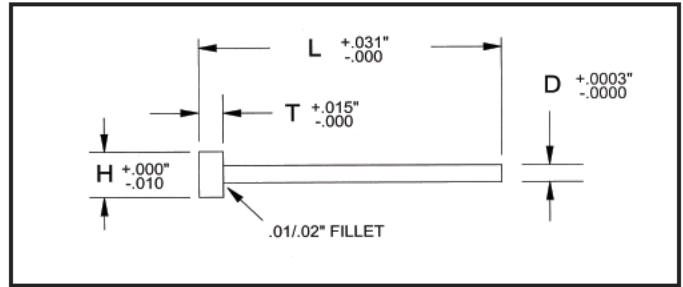

SQF TYPE: FRACTIONAL BLANKS

D BODY DIA. FRACTIONAL	H HEAD DIA.	T HEAD THICK	L OVERALL LENGTH	NET PRICE EACH PER QUANTITY (US\$)										
				TOOL STEEL					HIGH SPEED STEEL					
				100	50-99	25-49	10-24	1-9	100	50-99	25-49	10-24	1-9	
.0625"	*3/32	1/8	2-1/2"											
.0937"	5/32	1/8	2-1/2"	2.36	2.64	2.92	3.66	5.08	3.06	3.38	3.75	4.62	6.26	
.1250"	3/16	1/8	2-1/2"											
.1562"	7/32	1/8	2-1/2"	2.53	2.79	3.14	3.88	5.32	3.27	3.57	3.98	4.86	6.52	
.1875"	1/4	1/8	2-1/2"											
.2187"	9/32	1/8	2-1/2"	2.79	3.07	3.40	4.16	5.65	3.57	3.88	4.29	5.17	6.88	
.2500"	5/16	1/8	2-1/2"											
.3125"	7/16	3/16	2-1/2"	3.44	3.70	4.05	4.89	6.44	4.80	5.10	5.58	6.56	8.41	
.3750"	1/2	3/16	2-1/2"	3.61	3.86	4.27	5.10	6.66	5.10	5.42	5.88	6.88	8.80	

* Optional Head Diameter of 1/8 can be made to order. Price upon quotation

SQD TYPE: DECIMAL DIAMETERS IN .001" INCREMENTS

D BODY DIA. DECIMAL	H HEAD DIA.	T HEAD THICK	L OVERALL LENGTH	NET PRICE EACH PER QUANTITY (US\$)										
				TOOL STEEL					HIGH SPEED STEEL					
				100	50-99	25-49	10-24	1-9	100	50-99	25-49	10-24	1-9	
.030" - .062"	*3/32	1/8	2-1/2"											
.063" - .093"	5/32	1/8	2-1/2"	2.79	3.18	3.61	4.66	6.19	3.67	4.10	4.60	5.86	7.63	
.094" - .124"	3/16	1/8	2-1/2"											
.126" - .156"	7/32	1/8	2-1/2"	3.00	3.34	3.79	4.89	6.44	3.88	4.32	4.81	6.10	7.90	
.157" - .187"	1/4	1/8	2-1/2"											
.188" - .218"	9/32	1/8	2-1/2"	3.44	3.80	4.27	5.37	6.97	4.39	4.80	5.34	6.66	8.53	
.219" - .249"	5/16	1/8	2-1/2"											
.251" - .312"	7/16	3/16	2-1/2"	3.98	4.34	4.82	6.01	7.65	5.20	5.61	6.19	7.59	9.52	
.313" - .374"	1/2	3/16	2-1/2"	4.14	4.52	5.00	6.21	7.88	5.50	5.91	6.51	7.94	9.93	

* Optional Head Diameter of 1/8 can be made to order. Price upon quotation

QUANTITY DISCOUNTS
Based on one size, one shipment, and one destination
Over 300 Pieces Call For Pricing

Please see PAGE 1 for a complete list of modifications that are available for any of the ROYAL Family Of Pins and Punches

B AND AB TYPES



Royal

PERFORATORS/CORE PIN BLANKS

Ideal for tight center to center spacing in dies and molds
M-2 HIGH SPEED STEEL, 60-63 RC

PRECISION FORM-GROUND

DIAMETERS IN .001" INCREMENTS

The following fractional diameters are included in the .001" increment price tables below: 1/32, 3/64, 1/16, 5/64, 3/32, 7/64, 1/8, 9/64, 5/32, 3/16, 7/32, 1/4, 9/32, 5/16, & 3/8.

TYPE B STANDARD

TYPE AB: NON-STANDARD. CAN BE MADE TO ORDER FOR PROMPT DELIVERY IN THE SAME LENGTHS AND DIAMETER RANGES AS TYPE B. SAME PRICING APPLIES UP TO 250. *ABOVE 250 DIA. PER QUOTE.

2", 2-1/2", and 3" Lengths

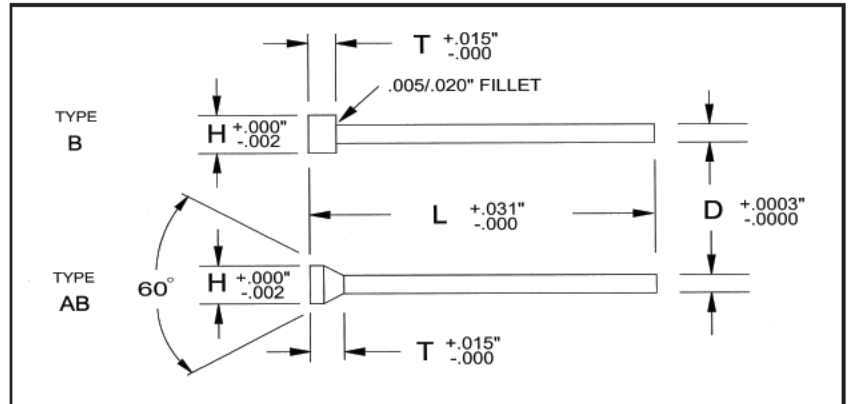

HOW TO ORDER: EXAMPLES				
Qty.	Cat No.	Dia.	X	Length
25	AB-4	.078	X	2-1/2
60	B-17	.269	X	3

Catalog No.		D	H	T	L		NET PRICE EACH PER QUANTITY					
AB TYPE	B TYPE	BODY DIA. .001" INCREMENTS	HEAD DIA.	HEAD THICK	OVERALL LENGTHS		100	50-99	25-49	10-24	5-9	1-4
1/0	1/0	.025 - .029	.060	3/32	2		4.90	5.24	5.83	6.89	8.57	9.96
1	1	.030 - .040	.070	3/32	2	2-1/2	4.42	4.74	5.27	6.23	7.75	9.36
2	2	.041 - .055	.085	3/32	2	2-1/2	4.25	4.49	5.05	5.96	7.40	8.81
3	3	.056 - .070	.100	3/32	2	2-1/2	3.97	4.20	4.66	5.51	6.83	8.20
4	4	.071 - .085	.115	3/32	2	2-1/2						
5	5	.086 - .100	.130	3/32	2	2-1/2						
6	6	.101 - .115	.145	3/32		2-1/2						
7	7	.116 - .130	.160	3/32		2-1/2	4.25	4.52	5.05	5.96	7.40	8.81
8	8	.131 - .145	.175	3/32		2-1/2						
9	9	.146 - .160	.190	3/32		2-1/2						
10	10	.161 - .175	.205	1/8		2-1/2	4.52	4.80	5.34	6.35	7.87	9.25
11	11	.176 - .190	.220	1/8		2-1/2						
12	12	.191 - .205	.235	1/8		2-1/2	4.63	4.93	5.50	6.52	8.10	9.49
13	13	.206 - .220	.250	1/8		2-1/2						
14	14	.221 - .235	.265	1/8		2-1/2						
15	15	.236 - .250	.280	1/8		2-1/2	4.90	5.17	5.80	6.88	8.57	9.96
16*	16	.251 - .265	.295	1/8		2-1/2						
17*	17	.266 - .280	.310	1/8		3	5.28	5.75	6.52	7.54	9.13	10.51
18*	18	.281 - .295	.325	1/8		3						
19*	19	.296 - .310	.340	1/8		3						
20*	20	.311 - .325	.355	3/16		3	5.57	6.02	6.84	7.93	9.61	10.98
21*	21	.326 - .340	.370	3/16		3						
22*	22	.341 - .355	.385	3/16		3	6.22	6.67	7.49	8.77	10.75	11.92
23*	23	.356 - .370	.400	3/16		3						
24*	24	.371 - .385	.415	3/16		3	6.77	7.06	8.12	9.52	11.69	13.07

QUANTITY DISCOUNTS

Based on one size, one shipment, and one destination

Over 300 Pieces Call For Pricing

Please see PAGE 1 for a complete list of modifications that are available for any of the ROYAL Family of Pins and Punches

CPB AND PPB TYPES



Royal

PUNCH BLANKS

M-2 HIGH SPEED STEEL, 60-63 RC
 HEADS DRAWN, 45-55 RC
 PRECISION FORM-GROUND
 FRACTIONAL BLANKS FROM 1/8 THROUGH 1"

2", 2-1/2", 3" and 3-1/2" Lengths

HOW TO ORDER: EXAMPLES				
Qty.	Cat. No.	Dia.	X	Length
12	CPB-25	1/4	X	2-1/2
6	PPB-75	3/4	X	3

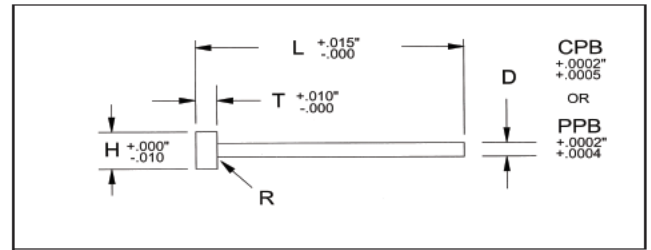

CPB (COMMERCIAL TOLERANCES) D: +.0002" / +.0005"

Catalog Number	D BODY DIA.	H HEAD DIA.	T HEAD THICK	L OVERALL LENGTHS				NET PRICE EACH PER QUANTITY (US \$)			
				50 +	25-49	10-24	1-9				
CPB-12	1/8	1/4	1/8	2"	2-1/2"			8.02	8.91	10.14	11.61
CPB-15	5/32	9/32	1/8	2"	2-1/2"						
CPB-18	3/16	5/16	1/8	2"	2-1/2"						
CPB-25	1/4	3/8	1/8	2"	2-1/2"	3"		8.98	9.90	11.29	12.88
CPB-31	5/16	7/16	1/8	2"	2-1/2"	3"					
CPB-37	3/8	1/2	3/16	2"	2-1/2"	3"		10.30	11.47	12.99	14.88
CPB-43	7/16	9/16	3/16	2"	2-1/2"	3"	3-1/2"				
CPB-50	1/2	5/8	3/16	2"	2-1/2"	3"	3-1/2"	10.30	11.47	12.99	14.88
CPB-62	5/8	3/4	1/4	2"	2-1/2"	3"	3-1/2"	14.60	16.15	18.34	21.12
CPB-75	3/4	7/8	1/4		2-1/2"	3"	3-1/2"	19.56	21.74	24.69	28.26
CPB-87	7/8	1"	1/4		2-1/2"	3"	3-1/2"	32.70	36.20	41.14	47.16
CPB-100	1"	1-1/8"	1/4		2-1/2"	3"	3-1/2"				

PPB (PRECISION TOLERANCES) D: +.0002" / +.0004"

Catalog Number	D BODY DIA.	H HEAD DIA.	T HEAD THICK	L OVERALL LENGTHS				NET PRICE EACH PER QUANTITY (US \$)			
				50 +	25-49	10-24	1-9				
PPB-12	1/8	1/4	1/8	2"	2-1/2"			8.98	9.90	11.29	12.88
PPB-15	5/32	9/32	1/8	2"	2-1/2"						
PPB-18	3/16	5/16	1/8	2"	2-1/2"						
PPB-25	1/4	3/8	3/16	2"	2-1/2"	3"		10.03	10.99	12.57	14.42
PPB-31	5/16	7/16	3/16	2"	2-1/2"	3"					
PPB-37	3/8	1/2	3/16	2"	2-1/2"	3"		11.62	12.75	15.22	16.69
PPB-43	7/16	9/16	3/16	2"	2-1/2"	3"	3-1/2"				
PPB-50	1/2	5/8	3/16	2"	2-1/2"	3"	3-1/2"	11.62	12.75	15.22	16.69
PPB-62	5/8	3/4	3/16		2-1/2"	3"	3-1/2"	15.69	17.95	19.66	22.70
PPB-75	3/4	7/8	3/16		2-1/2"	3"	3-1/2"	21.81	24.21	27.57	31.53
PPB-87	7/8	1"	3/16		2-1/2"	3"	3-1/2"	36.55	40.56	45.88	52.75
PPB-100	1"	1-1/8"	3/16		2-1/2"	3"	3-1/2"				

EB SLUG EJECTOR PUNCHES (WITH PPB DIMENSIONS)

CATALOG NUMBER	D BODY DIA.	H HEAD DIA.	T HEAD THICK.	L OVERALL LENGTHS				COMPONENT SE	PRICE PER QUOTE * UPON AVAILABILITY
				50 +	25-49	10-24	1-9		
EB-12	1/8	1/4	1/8	2"	2-1/2"			CS-2A	
EB-15	5/32	9/32	1/8	2"	2-1/2"			CS-3	
EB-18	3/16	5/16	1/8	2"	2-1/2"			CS-3	
EB-25	1/4	3/8	3/16	2"	2-1/2"			CS-3	
EB-31	5/16	7/16	3/16	2"	2-1/2"	3"		CS-4	
EB-37	3/8	1/2	3/16	2"	2-1/2"	3"		CS-6	
EB-43	7/16	9/16	3/16	2"	2-1/2"	3"	3-1/2"	CS-6	
EB-50	1/2	5/8	3/16	2"	2-1/2"	3"	3-1/2"	CS-6	

Please see PAGE 1 for a complete list of modifications that are available for any of the ROYAL Family Of Pins and Punches

MQA AND MQB TYPES



Royal

METRIC PERFORATORS/CORE PIN BLANKS

M-2 HIGH SPEED STEEL, 60-63 RC
PRECISION FORM-GROUND DIAMETERS

MADE TO ORDER
IN 0.01 mm INCREMENTS
10 PIECES MINIMUM

HOW TO ORDER: EXAMPLES				
Qty.	Type	Dia.	X	Length
50	MQA	0.95	X	63
25	MQB	6.55	X	63

63mm Length

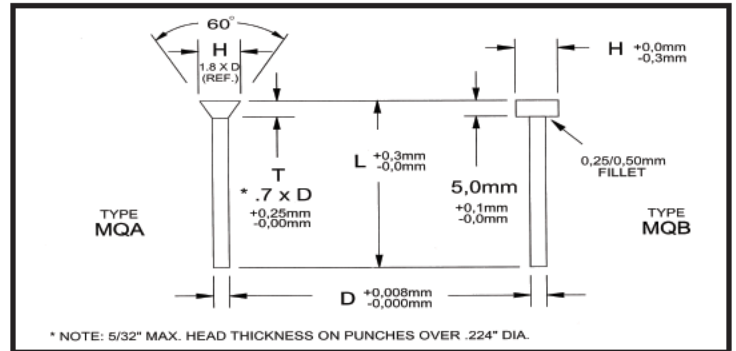

D DIAMETER RANGE MADE TO ORDER IN 0.01mm INCREMENTS	NET PRICE EACH PER QUANTITY (US \$)								MQB TYPE
	MQA				MQB				
	100+	50-99	25-49	10-24	100+	50-99	25-49	10-24	H
0.80mm - 1.60mm	2.79	3.55	4.93	8.53	4.21	5.13	7.22	13.94	3
1.61mm - 2.00mm	2.96	3.69	5.11	8.73	4.71	5.73	8.02	15.40	4
2.01mm - 3.00mm	3.28	4.04	5.64	9.09	4.71	5.73	8.02	15.40	5
3.01mm - 4.00mm	3.45	4.21	5.79	9.27	4.96	6.06	8.43	16.33	6
4.01mm - 5.00mm	3.79	4.64	6.06	9.81	5.13	6.22	8.71	16.89	7
5.01mm - 6.00mm	4.30	5.13	6.60	10.36	5.13	6.22	8.71	16.89	8
6.01mm - 7.00mm	4.71	5.64	7.14	11.00	5.38	6.56	9.24	17.78	9

MPB TYPE



Royal

METRIC PUNCH BLANKS

M-2 HIGH SPEED STEEL, RC 60-63
HEADS DRAWN 45-55 RC

MADE TO ORDER
10 PIECES MINIMUM

HOW TO ORDER: EXAMPLES			
QTY.	CAT No	X	LENGTH
50	MPB-3	X	63

50, 56, 63, 71, 80, 90, 100, and 125mm Lengths

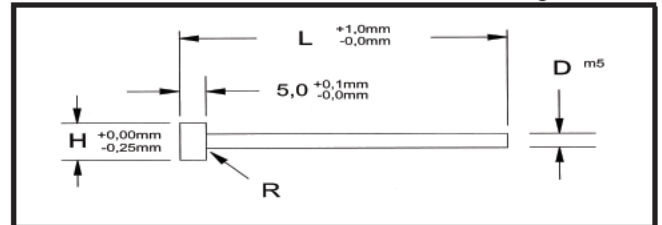

CATALOG NUMBER	D BODY DIA.		H HEAD DIA.	NET PRICE EACH PER QUANTITY (US \$)											
	NOM NAL DIA.	m ⁵ TOLERANCE		L-LENGTH											
				50, 56, & 63 mm			71 & 80 mm			90 & 100 mm			125 mm		
				50 +	25-49	10-24	50 +	25-49	10-24	50 +	25-49	10-24	50 +	25-49	10-24
MPB-3	3	+ 0,009 + 0,004	5.0	7.78	9.04	10.50	8.67	10.09	11.70	10.86	12.62	14.59	Q	Q	Q
MPB-4	4	+ 0,009 + 0,004	7.0	7.96	9.26	10.71	9.08	10.53	12.20	11.58	13.46	15.61	13.76	15.97	18.50
MPB-5	5	+ 0,009 + 0,004	8.0	9.24	10.74	12.44	9.97	11.56	13.41	11.64	13.50	15.72	13.90	16.15	18.72
MPB-6	6	+ 0,009 + 0,004	9.0	10.68	12.40	14.40	11.29	12.94	15.09	11.73	13.64	15.81	15.57	18.08	20.95
MPB-8	8	+ 0,012 + 0,006	11.0	11.31	13.15	15.24	11.72	13.74	16.20	12.30	14.28	16.58	16.05	18.63	21.60

Please see PAGE 1 for a complete list of modifications that are available for any of the ROYAL Family of Pins and Punches



BEVEL HEADED PUNCHES

TOOL STEEL, (TS)
(OHTS), 58-60 RC, HEADS DRAWN

HIGH SPEED STEEL (HSS)
M-2, 60-63 RC

Used by tool, die, stamping, and mold manufacturers as perforators, punches, knock-out pins, gauge pins, ejectors and core pins.

Special lengths can be made to order with prompt delivery. Please refer to the "Modify Length" column in the price table below.

When closer tolerance and better wear resistance is desired, please refer to Type RQA found on page 2. RQA perforators/core pin blanks are form-ground to $+ .0003"/-0"$ diameter tolerance, and are offered in M-2 HSS in diameter increments from .010" through .375".

Standard 2" and 2-1/2" Lengths

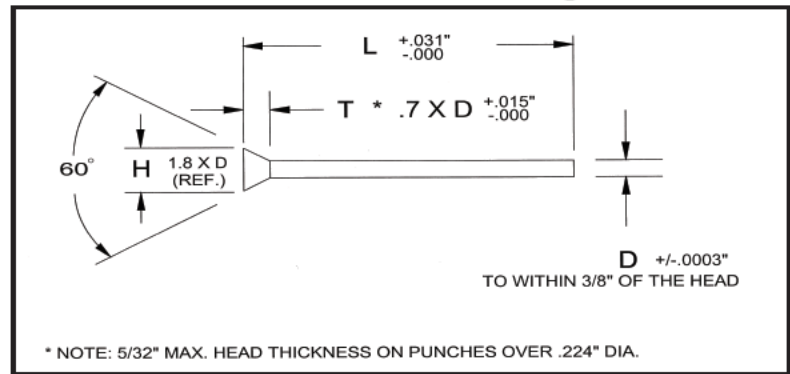

HOW TO ORDER: EXAMPLES					
Qty.	Type	Dia.	X	Length	Steel
100	BH	.062	X	2	TS
50	BH	.136	X	2-1/2	HSS

D STANDARD DIAMETERS .001 INCREMENTS	L LENGTHS	NET PRICE EACH PER QUANTITY (US\$)									
		TOOL STEEL					HIGH SPEED STEEL				
		100	50-99	25-49	10-24	1-9	100	50-99	25-49	10-24	1-9
.020" - .029"	2"	0.81	1.08	1.32	1.70	2.30	1.27	1.42	1.65	1.99	2.64
	2-1/2"	1.05	1.30	1.50	1.98	2.36	1.36	1.54	1.75	2.07	2.70
.030" - .039"	2"	0.79	1.04	1.29	1.68	2.22	1.18	1.38	1.60	1.93	2.54
	2-1/2"	1.02	1.27	1.45	1.92	2.34	1.28	1.47	1.68	2.02	2.66
.040" - .0625" (1/16)	2"	0.72	0.98	1.18	1.54	2.16	1.10	1.29	1.50	1.81	2.43
	2-1/2"	0.97	1.17	1.39	1.80	2.28	1.15	1.35	1.56	1.90	2.52
.063" - .0781" (5/64)	2"	0.72	0.98	1.18	1.54	2.16	1.10	1.29	1.50	1.81	2.43
	2-1/2"	0.97	1.17	1.39	1.80	2.28	1.15	1.35	1.56	1.90	2.52
.079" - .0937" (3/32)	2"	0.72	0.98	1.18	1.54	2.16	1.10	1.29	1.50	1.81	2.43
	2-1/2"	0.97	1.17	1.39	1.80	2.28	1.15	1.35	1.56	1.90	2.52
.094" - .1094" (7/64)	2"	0.86	1.11	1.38	1.75	2.49	1.53	1.69	1.90	2.28	2.94
	2-1/2"	1.11	1.40	1.64	2.06	2.66	1.58	1.77	2.00	2.36	3.01
.110" - .125" (1/8)	2"	0.86	1.11	1.38	1.75	2.49	1.53	1.69	1.90	2.28	2.94
	2-1/2"	1.11	1.40	1.64	2.06	2.66	1.58	1.77	2.00	2.36	3.01
.126" .127" .128"	2"	1.06	1.30	1.58	1.98	2.72	1.84	2.04	2.28	2.70	3.36
	2-1/2"	1.32	1.58	1.84	2.25	3.02	1.93	2.13	2.35	2.74	3.43
⊙ .129"	2"	1.57	1.84	2.13	2.53	3.33	2.32	2.50	2.77	3.15	3.91
	2-1/2"	1.82	2.10	2.36	2.83	3.57	2.37	2.58	2.83	3.27	4.02
.130"	2"	1.06	1.30	1.58	1.98	2.72	1.84	2.04	2.28	2.70	3.36
	2-1/2"	1.32	1.58	1.84	2.25	3.02	1.93	2.13	2.35	2.74	3.43
⊙ .131" - .134"	2"	1.57	1.84	2.13	2.53	3.33	2.32	2.50	2.77	3.15	3.91
	2-1/2"	1.82	2.10	2.36	2.83	3.57	2.37	2.58	2.83	3.27	4.02
.135"	2"	1.06	1.30	1.58	1.98	2.72	1.84	2.04	2.28	2.70	3.36
	2-1/2"	1.32	1.58	1.84	2.25	3.02	1.93	2.13	2.35	2.74	3.43
⊙ .136" - .139"	2"	1.57	1.84	2.13	2.53	3.33	2.32	2.50	2.77	3.15	3.91
	2-1/2"	1.82	2.10	2.36	2.83	3.57	2.37	2.58	2.83	3.27	4.02
.140" .1406" (9/64)	2"	1.06	1.30	1.58	1.98	2.72	1.84	2.04	2.28	2.70	3.36
	2-1/2"	1.32	1.58	1.84	2.25	3.02	1.93	2.13	2.35	2.74	3.43
⊙ .141" - .156"	2"	1.57	1.84	2.13	2.53	3.33	2.32	2.50	2.77	3.15	3.91
	2-1/2"	1.82	2.10	2.36	2.83	3.57	2.37	2.58	2.83	3.27	4.02
.1562" (5/32)	2"	1.06	1.30	1.58	1.98	2.72	1.84	2.04	2.28	2.70	3.36
	2-1/2"	1.32	1.58	1.84	2.25	3.02	1.93	2.13	2.35	2.74	3.43

⊙ Denotes Form-Ground Diameters



BEVEL HEADED PUNCHES

Standard 2" and 2-1/2" Lengths (Continued)

D STANDARD DIAMETERS .001" INCREMENTS	L LENGTHS	NET PRICE EACH PER QUANTITY (US\$)									
		TOOL STEEL					HIGH SPEED STEEL				
		100	50-99	25-49	10-24	1-9	100	50-99	25-49	10-24	1-9
⊙ .157" - .171"	2"	1.57	1.84	2.13	2.53	3.33	3.03	3.25	3.51	3.96	4.78
	2-1/2"	1.82	2.10	2.36	2.83	3.57	3.07	3.30	3.56	4.04	4.88
.1719" (11/64)	2"	1.06	1.30	1.58	1.98	2.72	2.60	2.79	3.02	3.46	4.27
	2-1/2"	1.32	1.58	1.84	2.25	3.02	2.65	2.84	3.09	3.52	4.29
⊙ .172" - .187"	2"	1.57	1.84	2.13	2.53	3.33	3.03	3.25	3.51	3.96	4.78
	2-1/2"	1.82	2.10	2.36	2.83	3.57	3.07	3.30	3.56	4.04	4.88
.1875" (3/16)	2"	1.06	1.30	1.58	1.98	2.72	2.60	2.79	3.02	3.46	4.27
	2-1/2"	1.32	1.58	1.84	2.25	3.02	2.65	2.84	3.09	3.52	4.29
⊙ .188" - .203"	2"	1.82	1.75	1.98	2.36	3.05	2.56	2.75	2.97	3.37	4.07
	2-1/2"	1.74	1.95	2.22	2.58	3.34	2.61	2.81	3.03	3.43	4.13
.2031" (13/64)	2"	1.32	1.58	1.84	2.25	3.06	2.65	2.84	3.09	3.52	4.29
	2-1/2"	1.57	1.84	2.13	2.54	3.33	2.68	2.89	3.16	3.61	4.38
⊙ .204" - .218"	2"	1.82	2.10	2.37	2.83	3.66	3.07	3.30	3.56	4.04	4.88
	2-1/2"	2.08	2.34	2.66	3.09	4.00	3.13	3.37	3.63	4.11	4.95
.2187" (7/32)	2"	1.32	1.58	1.84	2.25	3.06	2.65	2.84	3.09	3.52	4.29
	2-1/2"	1.57	1.84	2.13	2.54	3.33	2.68	2.89	3.16	3.61	4.38
⊙ .219" - .234"	2"	1.82	2.10	2.37	2.83	3.66	3.07	3.30	3.56	4.04	4.88
	2-1/2"	2.08	2.34	2.66	3.09	4.00	3.13	3.37	3.63	4.11	4.95
.2343" (15/64)	2"	1.32	1.58	1.84	2.25	3.06	2.65	2.84	3.09	3.52	4.29
	2-1/2"	1.57	1.84	2.13	2.54	3.33	2.68	2.89	3.16	3.61	4.38
⊙ .235" - .249"	2"	1.82	2.10	2.37	2.83	3.66	3.07	3.30	3.56	4.04	4.88
	2-1/2"	2.08	2.34	2.66	3.09	4.00	3.13	3.37	3.63	4.11	4.95
.250" (1/4)	2"	1.32	1.58	1.84	2.25	3.06	2.65	2.84	3.09	3.52	4.29
	2-1/2"	1.57	1.84	2.13	2.54	3.33	2.68	2.89	3.16	3.61	4.38
⊙ .251" - .2812" (9/32)	2"	2.10	2.34	2.66	3.09	4.00	3.21	3.45	3.68	4.21	5.06
	2-1/2"	2.44	2.74	3.03	3.52	4.44	3.27	3.50	3.76	4.27	5.08
⊙ .282" - .3125" (5/16)	2"	2.25	2.53	2.83	3.31	4.16	3.39	3.61	3.90	4.38	5.22
	2-1/2"	2.62	2.94	3.20	3.73	4.65	3.45	3.66	3.96	4.41	5.31
⊙ .313" - .3437" (11/32)	2"	2.34	2.60	2.88	3.39	4.29	3.61	3.86	4.09	4.64	5.50
	2-1/2"	2.67	2.98	3.27	3.76	4.74	3.67	3.90	4.20	4.68	5.56
⊙ .344" - .375" (3/8)	2"	2.34	2.60	2.88	3.39	4.29	3.93	4.20	4.46	5.02	5.97
	2-1/2"	2.67	2.98	3.27	3.76	4.74	4.00	4.24	4.56	5.10	6.04
⊙ .3906" (25/64) .4062" (13/32) .4219" (27/64) .4375" (7/16)	2"	Items in this size range are available per quotation									
	2-1/2"										
⊙ .4531" (29/64) .4688" (15/32) .4844" (31/64) .5000" (1/2)	2"										
	2-1/2"										

⊙ Denotes Form-Ground Diameters

QUANTITY DISCOUNTS

Based on one size, one shipment, and one destination

500 Pieces 100 pc. Price Less 10%

1,000 Pieces 100 pc. Price Less 15%

Please see PAGE 1 for a complete list of modifications that are available for any of the ROYAL Family of Pins and Punches



BEVEL HEADED PUNCHES

MATERIAL:

TOOL STEEL, (TS)
(OHTS), 58-60 RC, HEADS DRAWN

Used by tool, die, stamping, and mold manufacturers as perforators, punches, knock-out pins, gauge pins, ejectors and core pins.

When closer tolerance and better wear resistance is desired, please refer to Type RQA found on page 2. RQA Perforators/Core Pin Blanks are form-ground to $\pm .0003$ "/-0" diameter tolerance, and are offered in M-2 HSS in diameter increments from .010" through .375".

Standard 4" and 6" Lengths

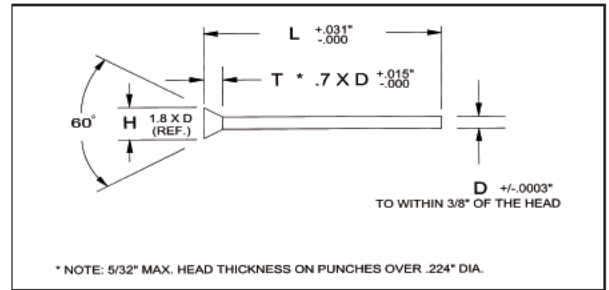

HOW TO ORDER EXAMPLES					
Qty.	Type	Dia.	X	Length	Steel
100	BH	5/32	X	6	TS
50	BH	15/64	X	4	TS

FRACTIONAL DIAMETERS TOOL STEEL ONLY FOR FRACTIONAL DIAMETERS IN M-2 HSS PLEASE REFER TO RQA TYPE ON PAGE 2						
D STANDARD DIAMETERS	L LENGTHS	PRICE PER EACH (US \$)				
		TOOL STEEL				
		100	50-99	25-49	10-24	1-9
1/16, 5/64	4"	1.83	2.14	2.73	3.43	4.48
	6"	2.34	2.66	3.25	4.09	5.23
3/32, 7/64	4"	1.82	2.11	2.62	3.30	4.27
	6"	2.32	2.60	3.19	3.92	5.00
1/8	4"	1.59	1.84	2.31	2.88	3.73
	6"	1.88	2.11	2.60	3.20	4.06
9/64, 5/32	4"	1.62	1.88	2.35	2.91	3.74
	6"	1.90	2.16	2.62	3.25	4.10
11/64, 3/16	4"	1.71	1.92	2.40	3.01	3.85
	6"	1.94	2.20	2.67	3.30	4.15
13/64, 7/32	4"	2.35	2.60	3.09	3.73	4.65
	6"	2.89	3.10	3.64	4.29	5.29
15/64, 1/4	4"	2.50	2.71	3.21	3.91	4.81
	6"	3.03	3.28	3.81	4.48	5.50
17/64, 9/32	4"	3.92	4.15	4.71	5.49	6.58
	6"	4.44	4.68	5.26	6.06	7.22
19/64, 5/16	4"	4.03	4.27	4.84	5.60	6.72
	6"	4.57	4.80	5.41	6.24	7.38
21/64, 11/32	4"	4.41	4.65	5.25	6.04	7.20
	6"	4.94	5.19	5.83	6.64	7.83
23/64, 3/8	4"	4.75	4.95	5.60	6.39	7.58
	6"	5.26	5.54	6.14	6.99	8.24

DECIMAL DIAMETERS TOOL STEEL ONLY FOR DECIMAL DIAMETERS IN M-2 HSS PLEASE REFER TO RQA TYPE ON PAGE 2 (10 PC. MINIMUM)				
D NON-STANDARD DECIMAL DIA.	PRICE PER EACH (US \$)			
	TOOL STEEL			
	100	50-99	25-49	10-24
.047"-.078"	3.90	4.77	7.26	14.01
	Q	Q	Q	Q
.079"-.109"	3.76	4.51	6.79	12.79
	4.33	5.60	8.49	14.76
.110"-.124"	3.30	3.97	5.98	11.28
	3.54	4.53	6.91	12.03
.126"-.156"	3.40	4.10	6.06	11.38
	3.62	4.68	7.03	12.16
.157"-.187"	3.54	4.21	6.19	11.77
	3.76	5.26	9.06	14.31
.188"-.218"	3.97	4.68	6.66	12.28
	4.41	5.91	9.75	15.12
.219"-.249"	4.21	4.88	6.91	12.55
	4.53	6.03	9.88	15.20
.251"-.281"	5.95	6.73	9.06	15.54
	6.84	8.31	12.25	17.76
.282"-.312"	6.08	6.85	9.20	15.69
	7.06	8.52	12.50	18.03
.313"-.343"	6.48	7.24	9.61	16.14
	7.38	8.89	12.86	18.42
.344"-.374"	6.73	7.51	9.88	16.44
	7.62	9.10	13.10	18.69

QUANTITY DISCOUNTS				
Based on one size, one shipment, and one destination				
500 Pieces	100 pc. Price Less 10%	1,000 Pieces 100 pc. Price Less 15%

Q = Price Per Quotation

Please see PAGE 1 for a complete list of modifications that are available for any of the ROYAL Family of Pins and Punches



DIE KICKER PINS - FORGED HEADS

MATERIAL : OIL HARDENING TOOL STEEL

HARDNESS : 58-62 RC, HEADS ANNEALED

This series is not recommended for Molding or Die Casting applications. Please refer to pages 14-22 for Ejector Pins and Core Pins for use in Molding and Die Casting.

4", 6", AND 10" LENGTHS

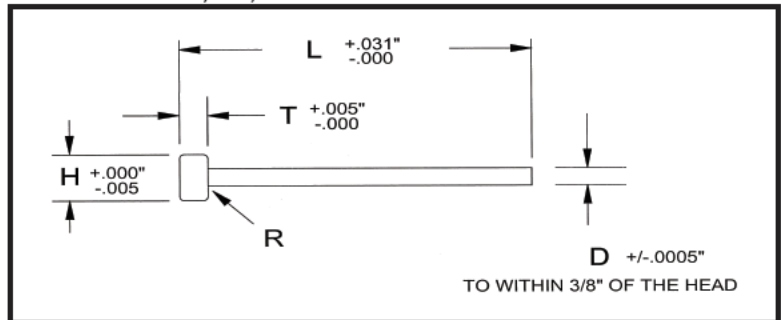

HOW TO ORDER: EXAMPLE				
Qty.	Cat No.	Dia.	X	Length
24	EP-9	1/8	X	6

CATALOG NUMBER	D BODY DIA.	H HEAD DIA.	T HEAD THICK	NET PRICE EACH PER QUANTITY (US \$)								
				L - LENGTHS								
				4"			6"			10"		
				100	50-99	1-49	100	50-99	1-49	100	50-99	1-49
EP-5	1/16	7/64	3/64	3.21	3.70	4.39	4.22	4.71	5.52	Q	Q	Q
EP-6	5/64	9/64	3/64	3.01	3.43	4.06	3.93	4.39	5.11	Q	Q	Q
EP-7	3/32	5/32	5/64	2.86	3.30	3.92	3.78	4.22	4.94	Q	Q	Q
EP-8	7/64	3/16	5/64	3.01	3.43	4.06	3.88	4.36	5.08	Q	Q	Q
EP-9	1/8	7/32	3/32	2.67	3.00	3.55	3.42	3.82	4.46	4.62	5.13	5.89
EP-10	9/64	1/4	7/64	2.67	3.00	3.55	3.42	3.82	4.46	4.62	5.13	5.89
EP-11	5/32	17/64	1/8	2.67	3.00	3.55	3.42	3.82	4.46	4.62	5.13	5.89
EP-12	11/64	5/16	1/8	2.79	3.18	3.74	3.56	4.02	4.63	4.78	5.26	6.07
EP-13	3/16	5/16	9/64	2.79	3.18	3.74	3.56	4.02	4.63	4.78	5.26	6.07
EP-14	13/64	11/32	5/32	3.07	3.45	4.05	3.68	4.11	4.77	4.93	5.42	6.22
EP-15	7/32	3/8	5/32	3.32	3.72	4.34	3.96	4.39	5.08	5.22	5.72	6.55
EP-16	15/64	13/32	11/64	3.42	3.82	4.46	4.22	4.68	5.38	5.34	5.88	6.74
EP-17	1/4	7/16	3/16	3.42	3.82	4.46	4.22	4.68	5.38	5.34	5.88	6.74
EP-18	17/64	7/16	1/4	4.06	4.53	5.23	4.48	4.95	5.67	5.49	6.02	6.87
EP-19	9/32	7/16	1/4	4.06	4.53	5.23	4.48	4.95	5.67	5.49	6.02	6.87
EP-20	19/64	1/2	1/4	4.35	4.82	5.52	4.62	5.05	5.83	5.77	6.32	7.19
EP-21	5/16	1/2	1/4	4.35	4.82	5.52	4.62	5.05	5.83	5.77	6.32	7.19
EP-22	21/64	9/16	1/4	4.48	4.95	5.71	4.87	5.37	6.15	6.52	7.08	8.06
EP-23	11/32	9/16	1/4	4.48	4.95	5.71	4.87	5.37	6.15	6.52	7.08	8.06
EP-24	23/64	5/8	1/4	4.62	5.05	5.83	5.17	5.67	6.45	7.10	7.70	8.73
EP-25	3/8	5/8	1/4	4.62	5.05	5.83	5.17	5.67	6.45	7.10	7.70	8.73

QUANTITY DISCOUNTS

Based on one size, one shipment, and one destination

500 Pieces 100 pc. Price Less 10%

1,000 Pieces 100 pc. Price Less 15%

Q = Price Per Quotation

Please see PAGE 1 for a complete list of modifications that are available for any of the ROYAL Family of Pins and Punches

EJ TYPE

SLUG EJECTOR COMPONENTS



Royal

REPLACEMENT SLUG EJECTOR COMPONENTS FOR SHOULDER HEAD AND BALL-LOCK TYPE EJECTOR PUNCHES.

HOW TO ORDER: EXAMPLES	
Qty.	Cat. No.
20	EJ-3
50	CS-6

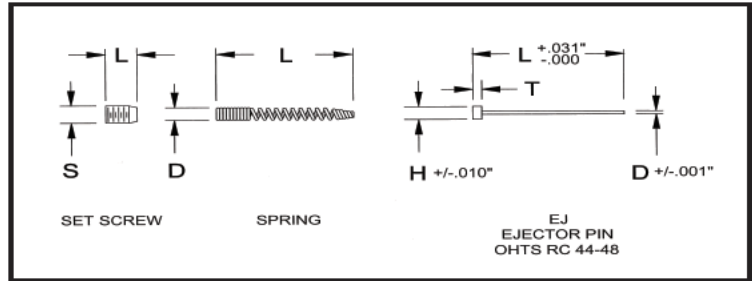

PINS ONLY (MINIMUM ORDER QTY. 10 PCS.)

CATALOG NUMBER	D	H	T	L	NET PRICE EACH PER QUANTITY (US \$)			
	PIN DIA.	HEAD DIA.	HEAD THICK	LENGTH	100	50-99	25-49	10-24
EJ-2	.015"	.048"	.031"	1.11"	3.38	3.87	4.92	6.04
EJ-2A	.020"	.048"	.031"	1.11"	1.75	2.30	3.30	4.41
EJ-3	.027"	.078"	.047"	1.38"	1.66	2.22	3.16	4.29
EJ-4	.041"	.094"	.062"	1.94"	1.66	2.22	3.16	4.29
EJ-6	.058"	.125"	.062"	1.94"	1.66	2.22	3.16	4.29
EJ-9	.089"	.156"	.094"	2.22"	1.75	2.30	3.30	4.41
EJ-12	.120"	.188"	.094"	2.22"	2.41	3.12	4.50	6.03

COMPONENT SETS (MINIMUM ORDER QTY. 10 PCS.)

(INCLUDES PINS, SPRINGS, & SET SCREWS)

CATALOG NUMBER	SPRING		SET SCREW		NET PRICE EACH PER QUANTITY (US \$)			
	D	L	S	L	100	50-99	25-49	10-24
	DIA.	LENGTH	THREAD	LENGTH				
CS-2	.062"	2"	2-56	.125"	4.92	5.38	6.55	7.68
CS-2A	.062"	2"	2-56	.125"	3.28	3.85	4.93	6.04
CS-3	.093"	2-1/2"	5-40	.125"	3.20	3.75	4.80	5.92
CS-4	.093"	2-1/2"	6-32	.125"	3.20	3.75	4.80	5.92
CS-6	.125"	3"	8-32	.125"	3.20	3.75	4.80	5.92
CS-9	.187"	3"	1/4-20	.250"	3.28	3.85	4.93	6.04
CS-12	.187"	3"	1/4-20	.250"	3.92	4.65	6.13	7.66

* Also available with 1/4-28 set screw at same price. Please specify when ordering

QUANTITY DISCOUNTS

Apply to EJ & CS, Based on one size, one shipment, and one destination

Over 500 Pieces Call For Pricing

SPRING ONLY (MINIMUM ORDER QTY. 10 PCS.)

CATALOG NUMBER	D	L	NET PRICE EA (US \$)
	DIA.	LENGTH	
S-2A	.062"	2"	.92
S-3	.093"	2-1/2"	.92
S-4	.093"	2-1/2"	.92
S-6	.125"	3"	.92
S-9	.187"	3"	.92
S-12	.187"	3"	.92

SET SCREW ONLY (MINIMUM ORDER QTY. 10 PCS.)

CATALOG NUMBER	S	L	NET PRICE EA (US \$)
	THREAD	LENGTH	
SS-2A	2-56	.125"	.73
SS-3	5-40	.125"	.73
SS-4	6-32	.125"	.73
SS-6	8-32	.125"	.73
SS-9	1/4-20	.250"	.73
SS-12	1/4-20	.250"	.73

MPT TYPE



Royal

METRIC M-2 TRUE-HARD™ SERIES EJECTOR PINS NON-STANDARD

MATERIAL: M-2 HIGH SPEED STEEL
THROUGH-HARDENED TO 60-63 RC
HEADS DRAWN TO 40-55 RC (SIZES 4.0 - 6.0 ONLY)

SHOULDER STYLE

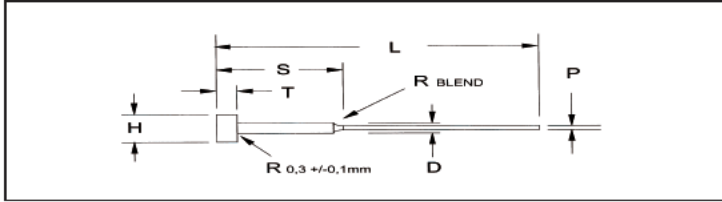

TOLERANCES (METRIC ISO)				
P	D	H	T	L
-0.002 mm	+0.00 mm	+0.00 mm	+0.00 mm	+1 mm
-0.008 mm	-0.02 mm	-0.2 mm	-0.05 mm	-0 mm

HOW TO ORDER EXAMPLES		
Qty.	Cat No.	Length
24	MPT-10-50	L-150
48	MPT-20-75	L-150

D SHLD. DIA.	H HEAD DIA.	T HEAD THICK	P PIN DIA.	S SHLD. LGTH.	CATALOG NUMBER	NET PRICE EACH (US \$)		PKG. QTY.	
						LENGTHS			
						L-150	L-200		
2	4	2	0.8	50	MPT-08-50	16.30	Q	12	
				75	MPT-08-75	16.30	Q		
			0.9	50	MPT-09-50	16.30	Q		
				75	MPT-09-75	16.30	Q		
			1.0	35	MPT-10-35	16.30	Q		
				50	MPT-10-50	16.30	19.75		
			75	MPT-10-75	15.88	17.24			
			1.1	50	MPT-11-50	16.30	17.14		
				75	MPT-11-75	15.88	16.30		
			1.2	50	MPT-12-50	16.30	17.14		
				75	MPT-12-75	15.88	16.30		
			1.3	50	MPT-13-50	14.97	16.99		
				75	MPT-13-75	14.54	16.15		
			1.4	50	MPT-14-50	14.97	16.82		
75	MPT-14-75	14.54		15.97					
3	6	3	1.5	35	MPT-15-35	13.28	17.34		
				50	MPT-15-50	13.28	14.78		
			75	MPT-15-75	12.87	13.95			
			1.6	50	MPT-16-50	12.70	14.64		
				75	MPT-16-75	12.62	13.80		
			1.7	50	MPT-17-50	12.51	14.46		
				75	MPT-17-75	12.45	13.63		
			1.8	50	MPT-18-50	12.27	14.31		
				75	MPT-18-75	12.19	13.46		
			1.9	50	MPT-19-50	11.85	14.12		
				75	MPT-19-75	11.79	13.28		
			2.0	50	MPT-20-50	11.35	13.80		
				75	MPT-20-75	11.28	12.96		
			2.2	50	MPT-22-50	11.02	13.46		
75	MPT-22-75	10.93		12.62					
2.5	35	MPT-25-35	10.60	14.54					
	50	MPT-25-50	10.60	12.87					
75	MPT-25-75	10.52	12.03						

STRAIGHT STYLE

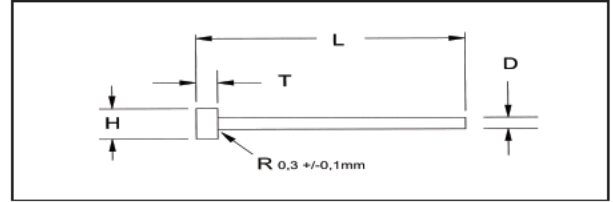

TOLERANCES (METRIC ISO)				
D	H	T	L	
0 to 3	-0.002 mm -0.008 mm	+0.0 mm	+0.00 mm	+1 mm
3 5 to 6	-0.004 mm -0.012 mm	-0.2 mm	-0.05 mm	-0 mm

HOW TO ORDER EXAMPLE		
Qty.	Cat No.	Length
24	MPT-35	L-150

D PIN DIA.	H HEAD DIA.	T HEAD THICK	CATALOG NUMBER	NET PRICE EACH (US \$)		PKG. QTY.	
				LENGTHS			
						L-150	L-200
2.0	4	2	MPT-20	11.11	19.50	12	
2.5	5	2	MPT-25	10.60	16.82		
3.0	6	3	MPT-30	8.00	13.28		
3.5	7	3	MPT-35	8.07	13.36		
4.0	8	3	MPT-40	8.07	13.36		
5.0	10	3	MPT-50	10.33	15.14		
6.0	12	5	MPT-60	10.33	15.14		

QUANTITY DISCOUNTS

Based on one shipment and one destination.

Apply to all MPT's in catalog and are combinable with PT, RHX, RX, ME, RC, and RCX Ejector Pins and Core Pins.

300 Pcs. (one size).....Less 5%

500 Pcs. (cumulative).....Less 5%

1200 Pcs. (cumulative).....Less 7%

Q = Price Per Quotation

PT AND PTD TRUE-HARD™ SERIES



Royal

M-2 EJECTOR/CORE PINS

MATERIAL : M-2 HIGH SPEED STEEL
THROUGH-HARDENED TO 60-63 RC

TIGHTEST TOLERANCE IN THE INDUSTRY (.0003")

SHOULDER STYLE

STANDARD FRACTIONAL AND .0001" INCREMENT DIAMETERS

Royal TRUE-HARD™ Ejector/Core Pins are made from superior quality, wear resistant M-2 high speed steel, through hardened and double tempered to 60-63 RC in our specially developed vacuum heat treating equipment which is computer regulated to produce maximum toughness and durability. The diameters are precision ground after hardening to insure the high accuracy and finish.

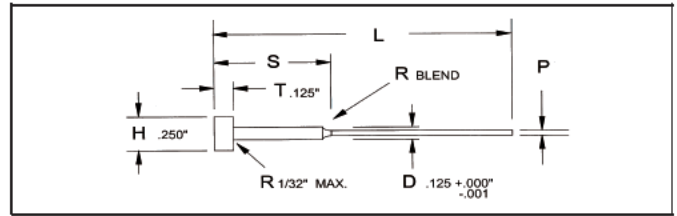

TOLERANCES				
P		H	T	L
PT -.0005"	PTD +.0000"	+ .000"	+ .000"	+.375"
-.0008"	-.0003"	-.010"	-.002"	-.000"

HOW TO ORDER EXAMPLES			
Qty.	Cat. No.	Length	P (If PTD)
12	PT-5-3	L-8	
36	PTD-7-2	L-6	P= 0925

PT TYPE STANDARD FRACTIONAL DIAMETERS 12 PINS PER PACKAGE					PTD TYPE NON-STANDARD DECIMAL DIAMETERS .0001" INCREMENTS															
P NOM. PIN DIA.	ACTUAL PIN DIA.	S SHL. LGTH.	CAT. NO.	L-6"		P DIA. RANGE	S SHL. LGTH.	CAT. NO.	L-6"					L-8"						
				STD. DIA.	STD. DIA.				NET PRICE EACH PER QUANTITY (US \$)					NET PRICE EACH PER QUANTITY (US \$)						
									50-99	25-49	10-24	5-9	1-4	50-99	25-49	10-24	5-9	1-4		
1/32	.0308" .0305"	1/2	PT-2-1/2	11.42	Q	UNDER .0312"	1/2	PTD-2-1/2	Q	Q	Q	Q	Q	Q	Q	Q	Q	Q	Q	
		2"	PT-2-2	10.51	11.28		2"	PTD-2-2	Q	Q	Q	Q	Q	Q	Q	Q	Q	Q	Q	
		3"	PT-2-3	Q	11.28		3"	PTD-2-3	Q	Q	Q	Q	Q	Q	Q	Q	Q	Q	Q	Q
		4"	PT-2-4	Q	9.60		4"	PTD-2-4	Q	Q	Q	Q	Q	Q	Q	Q	Q	Q	Q	Q
3/64	.0464" .0461"	1/2	PT-3-1/2	7.25	Q	.0313" THRU .0469"	1/2	PTD-3-1/2	10.17	12.28	18.84	23.16	28.40	Q	Q	Q	Q	Q	Q	
		2"	PT-3-2	7.08	9.14		2"	PTD-3-2	10.03	12.14	18.67	22.99	28.21	13.80	15.92	23.43	27.93	33.19		
		3"	PT-3-3	Q	9.14		3"	PTD-3-3	Q	Q	Q	Q	Q	13.80	15.92	23.43	27.93	33.19		
		4"	PT-3-4	Q	8.22		4"	PTD-3-4	Q	Q	Q	Q	Q	12.94	15.08	22.42	26.90	32.14		
1/16	.0620" .0617"	1/2	PT-5-1/2	6.24	11.58	.0470" THRU .0625"	1/2	PTD-5-1/2	9.25	11.36	17.74	22.02	27.25	Q	Q	Q	Q	Q	Q	
		2"	PT-5-2	6.01	8.22		2"	PTD-5-2	9.06	11.16	17.50	21.76	26.98	12.94	15.08	22.42	26.90	32.14		
		3"	PT-5-3	Q	8.22		3"	PTD-5-3	Q	Q	Q	Q	Q	12.94	15.08	22.42	26.90	32.14		
		4"	PT-5-4	Q	7.46		4"	PTD-5-4	Q	Q	Q	Q	Q	12.24	14.36	21.60	26.02	31.27		
5/64	.0776" .0773"	1/2	PT-6-1/2	6.24	11.58	.0626" THRU .0781"	1/2	PTD-6-1/2	9.25	11.36	17.74	22.02	27.25	Q	Q	Q	Q	Q	Q	
		2"	PT-6-2	6.01	8.22		2"	PTD-6-2	9.06	11.16	17.50	21.76	26.98	12.94	15.08	22.42	26.90	32.14		
		3"	PT-6-3	Q	8.22		3"	PTD-6-3	Q	Q	Q	Q	Q	12.94	15.08	22.42	26.90	32.14		
		4"	PT-6-4	Q	7.46		4"	PTD-6-4	Q	Q	Q	Q	Q	12.24	14.36	21.60	26.02	31.27		
3/32	.0933" .0930"	1/2	PT-7-1/2	5.78	9.14	.0782" THRU .0938"	1/2	PTD-7-1/2	8.85	10.94	17.25	21.49	26.73	Q	Q	Q	Q	Q	Q	
		2"	PT-7-2	5.54	7.14		2"	PTD-7-2	8.62	10.74	17.00	21.22	26.48	11.96	14.07	21.25	25.68	30.92		
		3"	PT-7-3	Q	7.14		3"	PTD-7-3	Q	Q	Q	Q	Q	11.96	14.07	21.25	25.68	30.92		
		4"	PT-7-4	Q	6.76		4"	PTD-7-4	Q	Q	Q	Q	Q	11.67	13.80	20.92	25.33	30.57		
7/64	.1089" .1086"	1/2	PT-8-1/2	5.78	9.14	.0939" THRU .1094"	1/2	PTD-8-1/2	8.85	10.94	17.25	21.49	26.73	Q	Q	Q	Q	Q	Q	
		2"	PT-8-2	5.54	7.14		2"	PTD-8-2	8.62	10.74	17.00	21.22	26.48	11.96	14.07	21.25	25.68	30.92		
		3"	PT-8-3	Q	7.14		3"	PTD-8-3	Q	Q	Q	Q	Q	11.96	14.07	21.25	25.68	30.92		
		4"	PT-8-4	Q	6.76		4"	PTD-8-4	Q	Q	Q	Q	Q	11.67	13.80	20.92	25.33	30.57		
Q = Price Per Quotation							.1095" THRU .1245"	1/2	PTD-9-1/2	6.68	8.77	14.67	18.79	24.02	Q	Q	Q	Q	Q	
								2"	PTD-9-2	6.45	8.62	14.41	18.52	23.76	10.60	12.73	19.68	24.02	29.28	
								3"	PTD-9-3	Q	Q	Q	Q	Q	10.60	12.73	19.68	24.02	29.28	
								4"	PTD-9-4	Q	Q	Q	Q	Q	10.33	12.44	19.35	23.67	28.92	



M-2 EJECTOR/CORE PINS

MATERIAL : M-2 HIGH SPEED STEEL
 THROUGH-HARDENED TO 60-63 RC
 HEADS DRAWN TO 40-55 RC (PT-11 THROUGH PT-17)

Royal TRUE-HARD™ Ejector/Core Pins are made from superior quality, wear resistant M-2 high speed steel, through hardened and double tempered to 60-63 RC in our specially developed vacuum heat treating equipment which is computer regulated to produce maximum toughness and durability. The diameters are precision ground after hardening to insure the high accuracy and finish.

STRAIGHT STYLE

STANDARD FRACTIONAL AND .0001" INCREMENT DIAMETERS

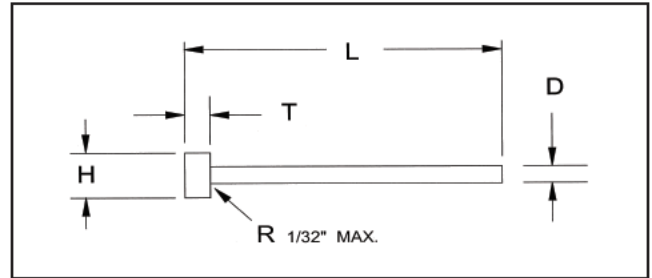

TOLERANCES				
D		H	T	L
PT -0.0005"	+0.0000"	+0.000"	+0.000"	+0.375"
-0.0008"	-0.0003"	-0.010"	-0.002"	-0.000"

HOW TO ORDER EXAMPLES			
Qty.	Cat. No.	Length	D (If PTD)
12	PT-9	L-8	
36	PTD-5	L-6	D= .0595

PT TYPE STANDARD FRACTIONAL DIAMETERS 12 P NS PER PACKAGE										PTD TYPE NON-STANDARD DECIMAL DIAMETERS .0001" INCREMENTS														
D		H	T	CAT. NO.	L-6"	L-8"	D	H	T	CAT. NO.	L-6"					L-8"								
NOM. PIN DIA.	ACTUAL PIN DIA.	HD. DIA.	HD. TK.		STD. DIA.	STD. DIA.		DIAMETER RANGE	HD. DIA.		HD. THK.	NET PRICE EACH PER QUANTITY (US\$)					NET PRICE EACH PER QUANTITY (US\$)							
											50-99	25-49	10-24	5-9	1-4	50-99	25-49	10-24	5-9	1-4				
1/32"	.0308" .0305"	1/4	1/8	PT-2	11.42	Q	UNDER .0312"	1/4	1/8	PTD-2	Q	Q	Q	Q	Q	Q	Q	Q	Q	Q	Q			
3/64"	.0464" .0461"			PT-3	7.25	Q	.0313" - .0469"			PTD-3	10.60	12.73	19.75	24.10	29.35	Q	Q	Q	Q	Q	Q	Q	Q	
1/16"	.0620" .0617"			PT-5	6.25	11.58	.0470"- .0625"			PTD-5	9.76	11.88	18.64	22.99	29.21	16.98	19.11	27.46	37.39	54.84				
5/64"	.0776" .0773"			PT-6	6.25	11.58	.0626"- .0781"			PTD-6	9.76	11.88	18.64	22.99	29.21	16.98	19.11	27.46	37.39	54.84				
3/32"	.0933" .0930"			PT-7	5.78	9.14	.0782"- .0938"			PTD-7	9.20	11.31	18.08	22.36	27.60	14.58	16.69	24.61	34.41	51.88				
7/64"	.1089" .1086"			PT-8	5.78	9.14	.0939"- .1094"			PTD-8	9.20	11.31	18.08	22.36	27.60	14.58	16.69	24.61	34.41	51.88				
1/8"	.1245" .1242"			PT-9	3.92	6.16	.1095"- .1250"			PTD-9	7.00	9.13	15.40	19.57	24.81	11.47	13.57	20.92	30.57	48.04				
9/64"	.1401" .1398"			PT-10	4.06	6.53	.1251"- .1406"			PTD-10	7.00	9.13	15.49	19.65	24.90	11.53	13.66	21.02	30.66	48.13				
5/32"	.1558" .1555"			9/32	5/32	PT-11	4.06			7.61	.1407"- .1562"	9/32	5/32	PTD-11	7.00	9.13	15.49	19.65	24.90	11.53	13.66	21.02	30.66	48.13
11/64"	.1714" .1711"			11/32	3/16	PT-12	5.33			7.61	.1563"- .1719"	11/32	3/16	PTD-12	8.85	10.96	17.59	21.84	27.09	13.10	15.20	22.87	32.59	50.06
3/16"	.1870" .1867"	3/8	3/16	PT-13	5.33	7.61	.1720"- .1875"	3/8	3/16	PTD-13	8.85	10.96	17.59	21.84	27.09	13.10	15.20	22.87	32.59	50.06				
13/64"	.2026" .2023"	3/8	3/16	PT-14	5.33	7.61	.1876"- .2031"	3/8	3/16	PTD-14	8.85	10.96	17.59	21.84	27.09	13.10	15.20	22.87	32.59	50.06				
7/32"	.2183" .2180"	13/32	3/16	PT-15	5.33	7.61	.2032"- .2187"	13/32	3/16	PTD-15	8.85	10.96	17.59	21.84	27.09	13.10	15.20	22.87	32.59	50.06				
15/64"	.2339" .2336"	13/32	3/16	PT-16	5.33	7.61	.2188"- .2343"	13/32	3/16	PTD-16	8.85	10.96	17.59	21.84	27.09	13.10	15.20	22.87	32.59	50.06				
1/4"	.2495" .2492"	7/16	3/16	PT-17	5.33	7.61	.2344"- .2500"	7/16	3/16	PTD-17	8.85	10.96	17.59	21.84	27.09	13.10	15.20	22.87	32.59	50.06				

QUANTITY DISCOUNTS		
ONE SHIPMENT AND ONE DESTINATION		
APPLY TO PT ONLY AND ARE COMBINABLE WITH RHX, RX, RC, RCX, ME AND MPT EJECTOR AND CORE PINS		
300 Pieces (ONE SIZE)....	Less 5%	500 Pieces (CUMULATIVE) ... Less 5%
1200 PCS. (CUMULATIVE)...	Less 7%	

Q = Price Per Quotation

Please see PAGE 1 for a complete list of modifications that are available for any of the ROYAL Family of Pins and Punches

H-13 "THROUGH-HARDENED" HOTWORK EJECTOR PINS

TIGHTEST TOLERANCE IN THE INDUSTRY (.0003")

MATERIAL : H-13 HOTWORK DIE STEEL

CORE: THROUGH-HARDENED TO 50-55 RC

SURFACE: ION NITRIDED TO 65-74 RC

HEADS: ANNEALED

TOLERANCES			
P	H	T	L
-.0005"	+.000"	+.000"	+.375"
-.0008"	-.010"	-.002"	-.000"

HOW TO ORDER: EXAMPLES			
Qty.	Cat No.	(IF .005" O.S.)	Length
24	RHX-7-1/2	+.005	L-10
48	RHX-3-2		L-6

SHOULDER STYLE

FRACTIONAL AND .005" OVERSIZED DIAMETERS

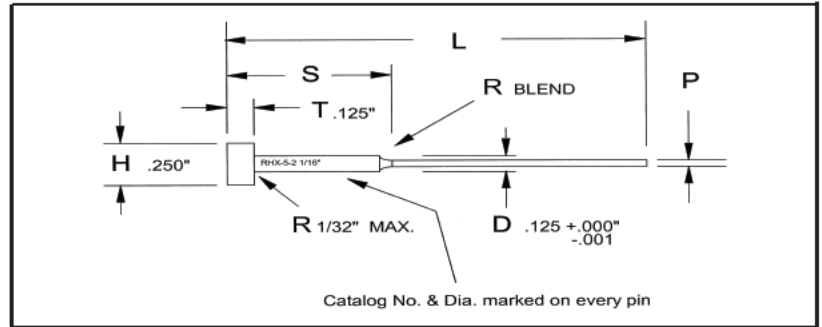

CATALOG NUMBER	P		S	NET PRICE EACH PER QUANTITY (US \$)					PKG. QTY.			
	PIN DIA.			SHOULDER LENGTH	L-6"			L-10"		L-14"		
	NOMINAL DIA.	DECIMAL EQUIV.			STANDARD DIA.	STANDARD DIA.	+.005" OVERSIZED DIA.	STANDARD DIA.		+.005" OVERSIZED DIA.		
RHX-2-1/2	1/32	0.03125	1/2"	7.35	Q	Q	Q	Q	12			
RHX-2-2			2"	7.25	Q	Q	Q	Q				
RHX-2-3			3"	Q	9.15	10.10	Q	Q				
RHX-2-4			4"	Q	9.15	10.10	Q	Q				
RHX-3-1/2	3/64	0.0469	1/2"	4.25	Q	Q	Q	Q				
RHX-3-2			2"	4.05	4.65	5.40	Q	Q				
RHX-3-3			3"	Q	5.10	6.15	Q	Q				
RHX-3-4			4"	Q	5.70	6.15	Q	Q				
RHX-5-1/2	1/16	0.0625	1/2"	3.95	4.90	5.60	Q	Q				
RHX-5-2			2"	3.85	4.50	5.40	6.20	7.15				
RHX-5-3			3"	Q	4.75	5.85	Q	Q				
RHX-5-4			4"	Q	5.30	6.45	Q	Q				
RHX-6-1/2	5/64	0.0781	1/2"	3.95	4.90	5.70	Q	Q				
RHX-6-2			2"	3.85	4.50	5.10	6.20	7.15				
RHX-6-3			3"	Q	4.75	5.85	Q	Q				
RHX-6-4			4"	Q	5.30	6.45	Q	Q				
RHX-7-1/2	3/32	0.0938	1/2"	3.60	4.55	5.10	Q	Q				
RHX-7-2			2"	3.40	4.30	4.90	5.80	6.75				
RHX-7-3			3"	Q	4.30	5.35	Q	Q				
RHX-7-4			4"	Q	4.75	5.85	Q	Q				
RHX-8-1/2	7/64	0.1094	1/2"	3.60	4.55	5.10	Q	Q				
RHX-8-2			2"	3.40	4.05	4.60	5.80	6.75				
RHX-8-3			3"	Q	4.30	5.35	Q	Q				
RHX-8-4			4"	Q	4.75	5.85	Q	Q				

Q = Price Per Quotation

Please see PAGE 1 for a complete list of modifications that are available for any of the ROYAL Family of Pins and Punches

H-13 "THROUGH-HARDENED" HOTWORK EJECTOR PINS

TIGHTEST TOLERANCES IN THE INDUSTRY (.0003")

MATERIAL : H-13 HOTWORK DIE STEEL

CORE: THROUGH-HARDENED TO 50-55 RC

SURFACE: ION NITRIDED TO 65-74 RC

HEADS: ANNEALED

STRAIGHT STYLE

FRACTIONAL AND .005" OVERSIZED DIAMETERS

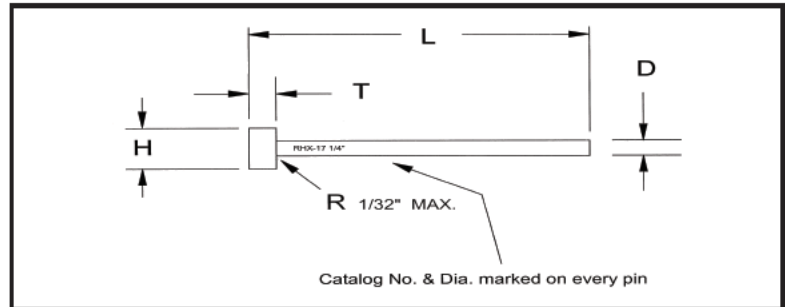

TOLERANCES			
D	H	T	L
-.0005"	+.000"	+.000"	+.375"
-.0008"	-.010"	-.002"	-.000"

HOW TO ORDER: EXAMPLES			
Qty.	Cat No.	(IF .005" O.S.)	Length
24	RHX-13	+.005	L-10
48	RHX-9		L-10

CATALOG NUMBER	D		H	T	NET PRICE EACH PER QUANTITY (US \$)					PKG. QTY.		
	PIN DIA.				HEAD DIA.	HEAD THICK.	L-6"	L-10"			L-14"	
	NOMINAL DIA.	DECIMAL EQUIV.					STANDARD DIA.	STANDARD DIA.	+.005" OVERSIZED DIA.		STANDARD DIA.	+.005" OVERSIZED DIA.
RHX-3	3/64	0.0469	1/4	1/8	4.30	Q	Q	Q	Q			
RHX-5	1/16	0.0625			4.05	4.75	5.30	Q	Q			
RHX-6	5/64	0.0781			4.05	4.75	5.30	Q	Q			
RHX-7	3/32	0.0938			3.65	4.10	4.85	Q	Q			
RHX-8	7/64	0.1094			3.65	4.10	4.85	Q	Q			
RHX-9	1/8	0.1250			1.95	2.15	2.25	2.50	2.80			
RHX-10	9/64	0.1406			2.15	2.35	3.15	3.05	Q			
RHX-11	5/32	0.1563	9/32	5/32	2.05	2.30	2.40	2.80	3.05			
RHX-12	11/64	0.1719	11/32	3/16	2.30	2.50	3.35	3.05	Q			
RHX-13	3/16	0.1875	3/8	3/16	2.10	2.45	2.55	3.10	3.30			
RHX-14	13/64	0.2031	3/8	3/16	2.55	2.70	Q	3.25	Q			
RHX-15	7/32	0.2188	13/32	3/16	2.30	2.70	2.95	3.35	Q			
RHX-16	15/64	0.2344	13/32	3/16	2.85	3.00	Q	3.70	Q			
RHX-17	1/4	0.2500	7/16	3/16	2.45	3.00	3.10	3.70	4.00			
RHX-18	17/64	0.2656	7/16	1/4	3.25	3.35	Q	4.05	Q			
RHX-19	9/32	0.2813	7/16	1/4	2.75	3.45	3.55	4.20	Q			
RHX-20	19/64	0.2969	1/2	1/4	3.65	3.80	Q	4.70	Q			
RHX-21	5/16	0.3125	1/2	1/4	3.05	3.80	3.90	4.75	5.25			
RHX-22	21/64	0.3281	9/16	1/4	4.00	4.20	Q	5.30	Q			
RHX-23	11/32	0.3438	9/16	1/4	3.40	4.30	4.55	5.50	Q			
RHX-24	23/64	0.3594	5/8	1/4	4.40	4.75	Q	5.95	Q			
RHX-25	3/8	0.3750	5/8	1/4	3.65	4.85	5.05	6.00	6.35			
RHX-26	25/64	0.3906	37/64	1/4	5.35	5.90	Q	Q	Q			
RHX-27	13/32	0.4063	11/16	1/4	4.00	5.30	5.70	6.90	Q			
RHX-28	27/64	0.4219	11/16	1/4	5.25	6.75	Q	Q	Q			
RHX-29	7/16	0.4375	11/16	1/4	4.35	5.90	6.15	7.60	8.40			
RHX-30	29/64	0.4531	45/64	1/4	5.70	7.05	Q	Q	Q			
RHX-31	15/32	0.4688	3/4	1/4	5.10	6.45	6.85	9.30	Q			
RHX-32	31/64	0.4844	3/4	1/4	6.20	8.15	Q	Q	Q			
RHX-33	1/2	0.5000	3/4	1/4	5.15	6.95	7.45	9.15	9.75			

12

Q = Price Per Quotation

QUANTITY DISCOUNTS

Apply to all standard RHX Shoulder and Straight Styles, and are combinable with PT, RX, RC, RCX, MPT, and ME Ejector and Core Pins

300 Pieces (one size).....Less 5% 500 Pieces (cumulative).....Less 5% 1200 Pieces (cumulative).....Less 7%

H-13 HOTWORK EJECTOR PINS

TIGHTEST TOLERANCES IN THE INDUSTRY (.0003")

MATERIAL : H-13 HOTWORK DIE STEEL

CORE: THROUGH-HARDENED TO 41-45 RC

SURFACE: ION NITRIDED TO 65-74 RC

Royal KNIGHTRIDE™ Series Ejector Pins are precision crafted from the finest grade of H-13 thermal shock resistant hotwork die steel. The heads are hot forged and stress relieved for uniform grain flow and high tensile strength. The core is through hardened to 41-45 RC and the surface is ion nitrided to 65-74 RC in a proprietary process, designed to create a diffusion layer between the nitrided case and the hardened core. The process produces the ideal combination of toughness and long life and it also prevents surface nicking and flaking which may be a problem with other nitrided pins. The diameters are precision ground to a high surface finish (5-10 Ra) and tight tolerance (.0003") which reduces friction and increases pin life.

SHOULDER STYLE

STANDARD FRACTIONAL AND .005" OVERSIZED DIAMETERS

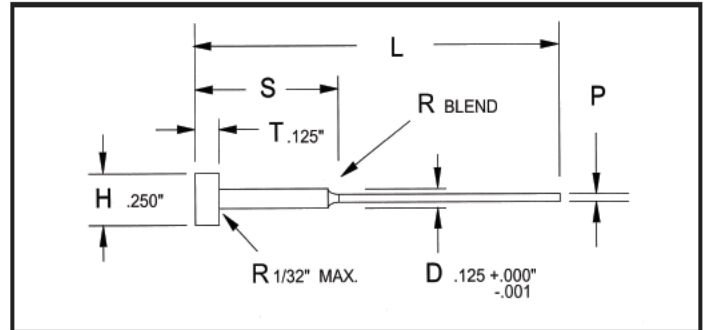

HOW TO ORDER: EXAMPLES			
Qty.	Cat No.	(IF .005" O.S.)	Length
24	RX-3-2		L-6
48	RX-5-1/2	+.005	L-10

TOLERANCES			
P	H	T	L
-.0005"	+.000"	+.000"	+.375"
-.0008"	-.010"	-.002"	-.000"

P		S	CATALOG NUMBER	L-4"	L-6"	L-10"		L-14"	PKG. QTY.
NOMINAL PIN DIA.	ACTUAL PIN DIA.	SHOULDER LENGTH		STANDARD DIA.	STANDARD DIA.	STANDARD DIA.	+.005" DIA.	STANDARD DIA.	
1/32	.0308" .0305"	1/2	RX-2-1/2	Q	6.51	Q	Q	Q	12
		2"	RX-2-2	Q	6.41	Q	Q	Q	
		3"	RX-2-3	Q	Q	8.04	Q	Q	
		4"	RX-2-4	Q	Q	8.04	Q	Q	
3/64	.0464" .0461"	1/2	RX-3-1/2	3.89	3.94	4.99	5.68	6.94	
		2"	RX-3-2	3.86	3.91	4.69	5.47	6.72	
		3"	RX-3-3	Q	Q	4.69	Q	Q	
		4"	RX-3-4	Q	Q	4.69	Q	Q	
1/16	.0620" .0617"	1/2	RX-5-1/2	3.52	3.56	4.56	5.36	6.40	
		2"	RX-5-2	3.43	3.48	4.35	5.15	6.04	
		3"	RX-5-3	Q	Q	4.18	Q	Q	
		4"	RX-5-4	Q	Q	4.35	Q	Q	
5/64	.0776" .0773"	1/2	RX-6-1/2	3.52	3.56	4.56	5.36	6.40	
		2"	RX-6-2	3.43	3.48	4.35	5.15	6.04	
		3"	RX-6-3	Q	Q	4.18	Q	Q	
		4"	RX-6-4	Q	Q	4.35	Q	Q	
3/32	.0933" .0930"	1/2	RX-7-1/2	3.16	3.21	4.14	4.92	6.07	
		2"	RX-7-2	3.08	3.12	3.93	4.70	5.92	
		3"	RX-7-3	Q	Q	3.76	Q	Q	
		4"	RX-7-4	Q	Q	3.93	Q	Q	
7/64	.1089" .1086"	1/2	RX-8-1/2	3.16	3.21	4.14	4.92	6.07	
		2"	RX-8-2	3.08	3.12	3.93	4.70	5.80	
		3"	RX-8-3	Q	Q	3.76	Q	Q	
		4"	RX-8-4	Q	Q	3.93	Q	Q	

Q=Price Per Quotation

QUANTITY DISCOUNTS	
Apply to all standard RX Shoulder and Straight Styles, and are combinable with PT, RHX, RC, RCX, MPT, and ME Ejector and Core Pins	
300 Pieces (one size).....Less 5%	500 Pieces (cumulative).....Less 5% 1200 Pieces (cumulative).....Less 7%

Please refer to pages 15 and 16 for our M-2 High Speed Steel TRUE-HARD™ Series Ejector/Core Pins. The TRUE-HARD™ pins are stocked in standard fractional diameters, up to 1/4" (PT Type) and are available for quick delivery in .0001" increment diameters (PTD TYPE)

Please see PAGE 1 for a complete list of modifications that are available for any of the ROYAL Family of Pins and Punches

RX KNIGHTRIDE™ SERIES

Royal

H-13 HOTWORK EJECTOR PINS

TIGHTEST TOLERANCES IN THE INDUSTRY(.0003")

MATERIAL: H-13 HOTWORK DIE STEEL
 CORE: THROUGH-HARDENED TO 41-45 RC
 SURFACE: ION NITRIDED TO 65-74 RC

STRAIGHT STYLE

FRACTIONAL AND .005" OVERSIZED AND LETTER SIZE DIAMETERS

TOLERANCES				
D	H	T	L	
UP TO 1/2" DIA. AND UP TO 14" LG.	-.0005" -.0008"	+ .000"	+ .000"	+ .375"
OVER 1/2" DIA. OR OVER 14" LG.	-.0003" -.0008"	- .010"	-.002"	-.000"

HOW TO ORDER: EXAMPLES				
Qty.	Cat No.	(F .005" O.S.)	Length	
25	RX-13	+ .005	L-10	
50	RX-5		L-10	

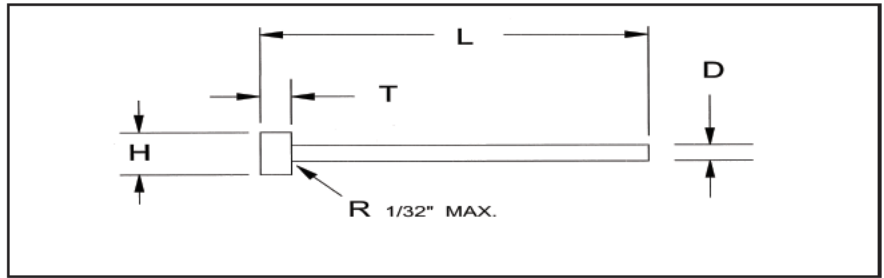

D		H	T	CATALOG NUMBER	L-4"	L-6"	L-10"	L-14"	L-18"	L-25"	L-36"	PKG. QTY.			
PIN DIA.		HEAD DIA.	HEAD THICK.		STD DIA.	STD DIA.	STD DIA.	+ .005" DIA.	STD DIA.	+ .005" DIA.	STD DIA.		+ .005" DIA.		
NOMINAL DIA.	DECIMAL EQUIV.														
1/32	0.0313	1/4	1/8	RX-2	Q	Q	Q	Q	Q	Q	Q	Q	12		
3/64	0.0469			RX-3	3.82	3.87	Q	Q	Q	Q	Q	Q		Q	
1/16	0.0625			RX-5	3.56	3.65	5.17	6.02	Q	Q	Q	Q		Q	
5/64	0.0781			RX-6	3.56	3.65	4.83	6.02	Q	Q	Q	Q		Q	
3/32	0.0938			RX-7	3.20	3.30	3.75	4.75	Q	Q	Q	Q		Q	
7/64	0.1094			RX-8	3.20	3.30	3.75	4.75	Q	Q	Q	Q		Q	
1/8	0.1250			RX-9	1.73	1.79	1.99	2.36	2.61	2.80	6.06	Q		Q	Q
9/64	0.1406			RX-10	Q	2.19	2.23	2.54	3.04	Q	5.77	Q		Q	Q
5/32	0.1563			RX-11	1.81	1.87	2.09	2.46	2.81	3.10	3.99	Q		Q	Q
11/64	0.1719			RX-12	2.18	2.24	2.50	2.89	3.32	Q	Q	Q		Q	Q
3/16	0.1875	3/8	3/16	RX-13	1.90	1.95	2.39	2.69	3.10	3.50	4.28	Q	6.12	Q	
13/64	0.2031			RX-14	Q	Q	2.74	Q	3.52	Q	Q	Q	Q	Q	
7/32	0.2188	13/32	3/16	RX-15	2.13	2.18	2.73	3.06	3.62	Q	Q	Q	6.63	Q	
15/64	0.2344			RX-16	Q	Q	3.00	Q	3.88	Q	Q	Q	Q	Q	
B	0.2380	7/16	3/16	RX-B	Q	Q	4.39	Q	Q	Q	Q	Q	Q	Q	
C	0.2420			RX-C	Q	Q	4.49	Q	Q	Q	Q	Q	Q	Q	
D	0.2460			RX-D	Q	Q	4.59	Q	Q	Q	Q	Q	Q	Q	
1/4	0.2500			RX-17	2.24	2.29	2.98	3.34	3.86	4.27	4.95	5.60	7.13	Q	
F	0.2570			RX-F	Q	Q	4.64	Q	Q	Q	Q	Q	Q	Q	
G	0.2610			RX-G	Q	Q	4.69	Q	Q	Q	Q	Q	Q	Q	
17/64	0.2656	7/16	1/4	RX-18	Q	Q	3.52	Q	4.21	Q	Q	Q	7.55	Q	
I	0.2720			RX-I	Q	Q	4.85	Q	Q	Q	Q	Q	Q	Q	
J	0.2770			RX-J	Q	Q	4.90	Q	Q	Q	Q	Q	Q	Q	
9/32	0.2813			RX-19	2.77	2.87	3.65	3.75	4.35	Q	5.80	Q	8.05	Q	
L	0.2900	1/2	1/4	RX-L	Q	Q	5.20	Q	Q	Q	Q	Q	Q		
M	0.2950			RX-M	Q	Q	5.25	Q	Q	Q	Q	Q	Q	Q	
19/64	0.2969			RX-20	Q	Q	3.86	Q	4.85	Q	Q	Q	Q	Q	
N	0.3020			RX-N	Q	Q	5.36	Q	Q	Q	Q	Q	Q	Q	
5/16	0.3125			RX-21	3.06	3.16	4.06	4.15	4.85	5.40	6.38	6.99	8.66	32.13	
P	0.3230			RX-P	Q	Q	5.66	Q	Q	Q	Q	Q	Q	Q	
21/64	0.3281	9/16	1/4	RX-22	Q	Q	4.35	Q	5.64	Q	Q	Q	9.37	Q	
Q	0.3320			RX-Q	Q	Q	5.87	Q	Q	Q	Q	Q	Q	Q	
R	0.3390			RX-R	Q	Q	5.97	Q	Q	Q	Q	Q	Q	Q	
11/32	0.3438			RX-23	3.51	3.56	4.55	4.70	5.73	Q	Q	Q	9.70	Q	
23/64	0.3594	5/8	1/4	RX-24	Q	Q	4.85	Q	6.13	Q	Q	Q	Q		
U	0.3680			RX-U	Q	Q	6.48	Q	Q	Q	Q	Q	Q	Q	
3/8	0.3750			RX-25	3.71	3.75	5.05	5.24	6.19	6.77	8.35	9.18	11.88	31.61	
V	0.3770			RX-V	Q	Q	6.63	Q	Q	Q	Q	Q	Q	Q	
W	0.3860			RX-W	Q	Q	6.63	Q	Q	Q	Q	Q	Q	Q	
X	0.3970			RX-X	Q	Q	6.99	Q	Q	Q	Q	Q	Q	Q	
Y	0.4040	11/16	1/4	RX-Y	Q	Q	7.14	Q	Q	Q	Q	Q	Q		
13/32	0.4063			RX-27	4.11	4.15	5.63	5.90	7.28	Q	9.60	Q	13.82	Q	
7/16	0.4375			RX-29	4.46	4.55	6.19	6.43	7.87	8.62	10.70	Q	15.45	34.31	
15/32	0.4688			RX-31	5.73	5.83	6.78	7.02	11.29	Q	11.82	Q	17.58	Q	
1/2	0.5000	RX-33	5.29	5.44	7.37	7.71	9.69	10.29	12.80	Q	19.02	37.98			
9/16	0.5625	13/16	1/4	RX-35	Q	6.72	9.17	Q	11.68	Q	15.25	Q	21.82	Q	
5/8	0.6250	7/8	1/4	RX-37	Q	7.79	10.76	Q	13.56	Q	17.60	Q	24.63	Q	
11/16	0.6875	15/16	1/4	RX-39	Q	10.26	12.69	Q	17.89	Q	25.76	Q	28.75	Q	
3/4	0.7500	1	1/4	RX-41	Q	10.86	14.58	Q	18.55	Q	26.76	Q	32.69	Q	
7/8	0.8750	1-1/8	1/4	RX-45	Q	23.30	27.40	Q	46.55	Q	65.75	Q	84.85	Q	
1	1.0000	1-1/4	1/4	RX-47	Q	24.40	27.40	Q	53.95	Q	69.80	Q	90.35	Q	

See previous page for Custom Modification information and Quantity Discounts. Q= Price Per Quotation

METRIC KNIGHTRIDE™ SERIES H-13 HOTWORK EJECTOR PINS

MATERIAL : H-13 HOTWORK DIE STEEL

CORE: THROUGH-HARDENED TO 41-45 RC

SURFACE: ION NITRIDED TO 65-74 RC

HEADS: ANNEALED

STRAIGHT STYLE

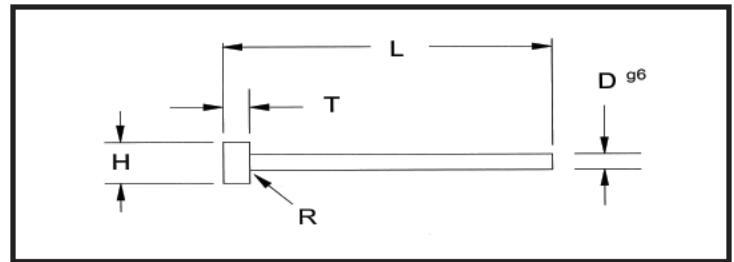

TOLERANCES (METRIC ISO)				
PIN DIA. (D)g6		R	Head Dia. (H)	+0.0 mm -0.2 mm
SIZE	TOLERANCE			
0 to 3 mm	-.002 mm -.008 mm	0.3 mm	Head Thick (T)	+0.00 mm -0.05 mm
3.5 to 6 mm	-.004 mm -.012 mm	0.3 mm		
6.5 to 10 mm	-.005 mm -.014 mm	0.5 mm	Length (L)	+2.0 mm -0.0 mm
11 to 18 mm	-.006 mm -.017 mm	0.8 mm		
20 to 25 mm	-.007 mm -.020 mm	0.8 mm		

HOW TO ORDER EXAMPLE		
Qty.	Cat. No.	Length
24	ME-2.5	L-160

CATALOG NUMBER	D PIN DIA.	H HEAD DIA.	T HEAD THICK.	NET PRICE EACH (US \$)				PKG. QTY
				LENGTHS				
				L-160	L-250	L-315	L-400	
ME-2.0	2.0	4	2	3.32	3.42	Q	Q	12
ME-2.5	2.5	5	2	3.37	3.67	4.28	Q	
ME-3.0	3.0	6	3	2.60	3.83	4.08	4.56	
ME-3.5	3.5	7	3	3.98	4.69	5.66	Q	
ME-4.0	4.0	8	3	2.81	4.18	4.49	5.30	
ME-4.5	4.5	8	3	4.39	5.51	6.27	Q	
ME-5.0	5.0	10	3	3.01	3.88	4.95	6.14	
ME-5.5	5.5	10	3	4.64	5.87	6.73	Q	
ME-6.0	6.0	12	5	3.77	5.41	6.27	7.88	
ME-6.5	6.5	12	5	5.15	7.19	8.31	Q	
ME-7.0	7.0	12	5	5.51	7.85	8.98	Q	
ME-8.0	8.0	14	5	4.90	7.19	8.52	10.61	
ME-9.0	9.0	14	5	6.63	10.10	11.63	Q	
ME-10.0	10.0	16	5	5.76	8.67	10.15	12.50	
ME-11.0	11.0	16	5	8.77	13.46	15.91	Q	
ME-12.0	12.0	18	7	6.78	9.79	13.46	Q	
ME-12.5	12.5	18	7	8.26	11.73	15.35	Q	
ME-14.0	14.0	22	7	8.57	12.65	Q	Q	6
ME-16.0	16.0	22	7	9.59	14.59	Q	Q	
ME-18.0	18.0	24	7	Q	19.18	Q	Q	
ME-20.0	20.0	26	8	Q	22.44	Q	Q	4
ME-25.0	25.0	32	10	Q	39.22	Q	Q	2

Q = Price Per Quotation

QUANTITY DISCOUNTS		
Apply to all standard ME Pins, and are combinable with PT, RHX, RC, RCX, MPT, and RX Ejector and Core Pins - One shipment, one destination		
300 Pieces (one size).....Less 5%	500 Pieces (cumulative).....Less 5%	1200 Pieces (cumulative).....Less 7%

Please see PAGE 1 for a complete list of modifications that are available for any of the ROYAL Family of Pins and Punches

RC AND RCX TYPES



STANDARD H-13 CORE PINS

3", 6" and 10" Lengths

TWO HARDNESS RANGES

STANDARD HARDNESS - RC TYPE: 30-35 RC

HIGH HARDNESS - RCX TYPE: 50-55-RC

RCX - Heads annealed

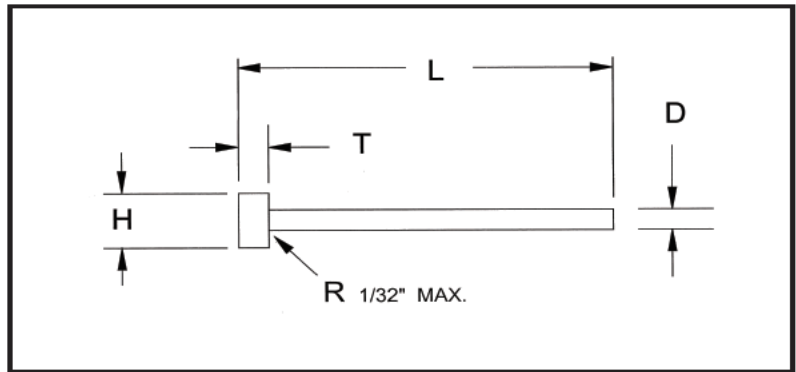

HOW TO ORDER: EXAMPLES		
QTY.	CAT NO.	LENGTH
24	RC-9	L-6
12	RCX-13	L-3

RC TYPE STANDARD HARDNESS 30-35 RC				D	H	T	RCX TYPE HIGH HARDNESS 50-55 RC				PKG. QTY.
CATALOG NUMBER	NET PRICE EACH (US \$)			BODY DIA.	HEAD DIA.	HEAD THICK.	CATALOG NUMBER	NET PRICE EACH (US \$)			
	STANDARD LENGTHS							STANDARD LENGTHS			
	L-3"	L-6"	L-10"					L-3"	L-6"	L-10"	
RC-3	4.90	5.51	Q	3/64	1/4	1/8	RCX-3	5.10	5.76	Q	12
RC-5	4.64	5.15	Q	1/16	1/4	1/8	RCX-5	4.85	5.41	Q	
RC-6	4.23	4.64	Q	5/64	1/4	1/8	RCX-6	4.44	4.90	Q	
RC-7	3.62	3.72	4.34	3/32	1/4	1/8	RCX-7	3.83	3.98	4.69	
RC-8	3.72	3.88	4.59	7/64	1/4	1/8	RCX-8	3.93	4.08	4.90	
RC-9	2.24	2.30	3.06	1/8	1/4	1/8	RCX-9	2.40	2.50	3.21	
RC-10	2.24	2.35	3.06	9/64	1/4	1/8	RCX-10	2.40	2.60	3.21	
RC-11	2.30	2.40	3.11	5/32	9/32	5/32	RCX-11	2.50	2.60	3.21	
RC-12	2.30	2.40	3.21	11/64	11/32	3/16	RCX-12	2.55	2.65	3.42	
RC-13	2.35	2.45	3.26	3/16	3/8	3/16	RCX-13	2.55	2.70	3.42	
RC-14	2.40	2.50	3.32	13/64	3/8	3/16	RCX-14	2.60	2.75	3.57	
RC-15	2.45	2.60	3.42	7/32	13/32	3/16	RCX-15	2.65	2.81	3.57	
RC-16	3.42	3.98	Q	15/64	13/32	3/16	RCX-16	3.62	4.23	Q	
RC-17	2.65	2.75	3.67	1/4	7/16	3/16	RCX-17	2.86	3.01	3.88	
RC-18	3.67	4.23	Q	17/64	7/16	1/4	RCX-18	3.93	4.54	Q	
RC-19	2.91	3.01	4.03	9/32	7/16	1/4	RCX-19	3.16	3.32	4.34	
RC-20	3.98	4.54	Q	19/64	1/2	1/4	RCX-20	4.23	4.85	Q	
RC-21	3.21	3.32	4.44	5/16	1/2	1/4	RCX-21	3.47	3.62	4.79	
RC-22	4.23	4.85	Q	21/64	9/16	1/4	RCX-22	4.54	5.20	Q	
RC-23	3.47	3.62	4.79	11/32	9/16	1/4	RCX-23	3.77	3.98	5.30	
RC-24	4.64	5.25	Q	23/64	5/8	1/4	RCX-24	4.90	5.61	Q	
RC-25	3.88	4.03	5.30	3/8	5/8	1/4	RCX-25	4.13	4.39	5.81	
RC-27	4.34	4.54	5.76	13/32	11/16	1/4	RCX-27	4.64	4.95	6.32	
RC-29	4.69	4.85	6.32	7/16	11/16	1/4	RCX-29	5.00	5.20	6.94	
RC-31	5.20	5.41	6.89	15/32	3/4	1/4	RCX-31	5.56	5.97	7.60	
RC-33	5.56	5.76	7.40	1/2	3/4	1/4	RCX-33	5.87	6.27	8.21	
RC-35	Q	6.89	9.18	9/16	13/16	1/4	RCX-35	Q	7.50	10.00	6
RC-37	Q	8.21	10.76	5/8	7/8	1/4	RCX-37	Q	8.77	11.88	
RC-39	Q	13.26	Q	11/16	15/16	1/4	RCX-39	Q	14.18	Q	
RC-41	Q	11.12	14.69	3/4	1	1/4	RCX-41	Q	12.09	16.32	

TOLERANCES		
D	PIN DIA.	+ .001" - .000"
H	HEAD DIA.	+ .000" - .010"
T	HEAD THICK.	+ .000" - .002"
L	OVERALL LENGTH	+ .375" - .000"

QUANTITY DISCOUNTS	
Based on one shipment and one destination	
Combinable with PT, RX, ME, RHX, and MPT Ejector pins.	
300 Pcs. (one size)...	Less 5%
500 Pcs. (cumulative)...	Less 5%
1200 Pcs. (cumulative)...	Less 7%

* Decimal diameters can be made to order for prompt delivery. Also, please refer to pages 2, 3, 4, 5, & 6 for core pin blanks stocked in .001" increments from 0.010" diameter.

Q = Price Per Quotation

Please see PAGE 1 for a complete list of modifications that are available for any of the ROYAL Family of Pins and Punches

MATERIAL: H-13 HOTWORK DIE STEEL
I. D. & O. D. NITRIDED TO 65-74 RC

NITRIDED O.D. & I.D.

TOLERANCES				
I.D.	O.D.	HEAD DIA.	HD. THICK	O.A.L.
A	D	H	T	L
+ .0005" - .0000"	- .0003" - .0008"	+ .000" - .010"	+ .000" - .002"	+ .125" - .000"

HOW TO ORDER: EXAMPLES		
Qty.	Cat. No.	Length
10	RSL-15	L-4
6	RSL-29	L-7

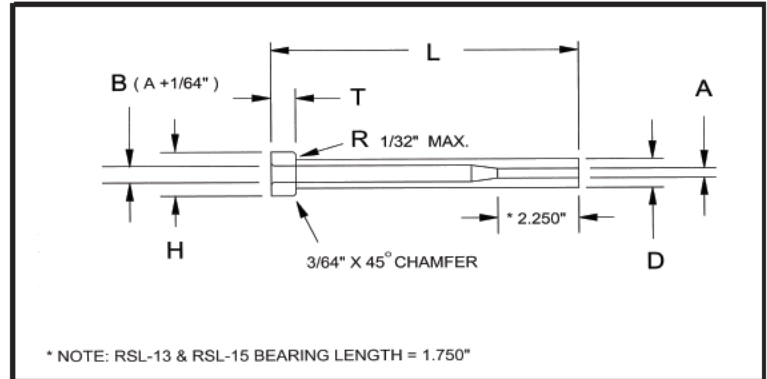

CATALOG NUMBER	A I.D.	D O.D.	H HEAD DIA.	T HEAD THICK	NET PRICE EACH PER QUANTITY (US \$)									
					L-3"		L-4"		L-5"		L-6"		L-7"	
					1-24	25 +	1-24	25 +	1-24	25 +	1-24	25 +	1-24	25 +
RSL-13	3/32	3/16	3/8	3/16	26.35	25.03	28.65	27.22	31.45	29.88	33.95	32.25	37.00	35.15
RSL-15	1/8	7/32	13/32	3/16	25.10	23.85	27.90	26.51	30.90	29.36	33.45	31.78	36.50	34.68
RSL-17	5/32	1/4	7/16	3/16	Q	Q	21.30	20.24	22.30	21.19	24.10	22.90	26.35	25.03
RSL-21	3/16	5/16	1/2	1/4	Q	Q	21.80	20.71	23.05	21.90	25.10	23.85	27.65	26.27
RSL-23	7/32	11/32	9/16	1/4	Q	Q	22.05	20.95	23.60	22.42	25.60	24.32	28.40	26.98
RSL-25	1/4	3/8	5/8	1/4	Q	Q	22.55	21.42	24.10	22.90	26.35	25.03	28.90	27.46
RSL-29	5/16	7/16	11/16	1/4	Q	Q	23.05	21.90	25.60	24.32	28.15	26.74	30.90	29.36
RSL-33	3/8	1/2	3/4	1/4	Q	Q	23.60	22.42	27.90	26.51	30.40	28.88	33.45	31.78
RSL-37	7/16	5/8	7/8	1/4	Q	Q	25.35	24.08	30.40	28.88	35.50	33.73	38.50	36.58
RSL-39	1/2	11/16	15/16	1/4	Q	Q	26.60	25.27	31.45	29.88	37.00	35.15	40.55	38.52
RSL-41	9/16	3/4	1"	1/4	Q	Q	33.00	31.35	36.50	34.68	40.00	38.00	44.00	41.80
RSL-45	5/8	7/8	1-1/8	1/4	Q	Q	37.50	35.63	41.00	38.95	45.00	42.75	49.00	46.55
RSL-47	3/4	1"	1-1/4	1/4	Q	Q	41.50	39.43	45.50	43.23	49.50	47.03	54.00	51.30

CATALOG NUMBER	A I.D.	D O.D.	H HEAD DIA.	T HEAD THICK	NET PRICE EACH PER QUANTITY (US \$)									
					L-8"		L-9"		L-10"		L-11"		L-12"	
					1-24	25 +	1-24	25 +	1-24	25 +	1-24	25 +	1-24	25 +
RSL-17	5/32	1/4	7/16	3/16	28.90	27.46	31.95	30.35	36.00	34.20	Q	Q	Q	Q
RSL-21	3/16	5/16	1/2	1/4	30.40	28.88	33.45	31.78	37.50	35.63	41.50	39.43	46.50	44.18
RSL-23	7/32	11/32	9/16	1/4	31.45	29.88	35.50	33.73	39.05	37.10	Q	Q	Q	Q
RSL-25	1/4	3/8	5/8	1/4	31.95	30.35	36.00	34.20	40.05	38.05	44.50	42.28	49.50	47.03
RSL-29	5/16	7/16	11/16	1/4	34.45	32.73	38.50	36.58	42.55	40.42	47.50	45.13	52.50	49.88
RSL-33	3/8	1/2	3/4	1/4	37.00	35.15	44.05	41.85	45.60	43.32	50.50	47.98	56.00	53.20
RSL-37	7/16	5/8	7/8	1/4	42.55	40.42	46.60	44.27	51.20	48.64	56.50	53.68	62.00	58.90
RSL-39	1/2	11/16	15/16	1/4	44.60	42.37	49.15	46.69	54.20	51.49	59.50	56.53	65.00	61.75
RSL-41	9/16	3/4	1"	1/4	48.00	45.60	53.00	50.35	57.50	54.63	63.00	59.85	68.50	65.08
RSL-45	5/8	7/8	1-1/8	1/4	53.50	50.83	58.50	55.58	63.50	60.33	69.50	66.03	75.00	71.25
RSL-47	3/4	1"	1-1/4	1/4	58.50	55.58	64.00	60.80	69.50	66.03	75.00	71.25	81.50	77.43

NOTE: Quantity Prices on Ejector Sleeves are per size only and are based on one shipment and one destination.

Ejector Sleeves are not combinable with any other components for cumulative pricing.

Q = Price Per Quotation

SIDE LOCKS



MALE - MATERIAL: Tool Steel With Black Oxide

HARDNESS: 58-62 RC

FEMALE - D-2: With Titanium Nitride Coating

CATALOG NUMBER	W +.0000" -.0004"	T +.000" -.002"	C	E +.000" -.002"	F +.000" -.010"	OVERALL HEIGHT	B1 +.010" -.010"	B2 +.010" -.010"	D +.000" -.002"	R +.010" -.000" RADIUS	SHCS (4)	PRICE
SL-100	1.0000	.375	.500	.875	530	2.000	.250	500	1.125	.187	10-32 X 1/2	123.50
SL-125	1.2500	.500	.500	.875	660	2.000	.250	.750	1.125	.187	8-32 X 5/8	134.45
SL-150	1.5000	.500	.563	.875	560	1.750	.250	1.000	.875	.187	8-32 X 5/8	136.42
SL-200	2.0000	.500	.750	.875	660	2.250	.312	1.375	1.375	.250	10-32 X 5/8	146.40
SL-300	3.0000	.750	1.250	.875	1.130	2.750	.375	2.250	1.875	.250	1/4-20 X 1	190.25
SL-400	4.0000	1.000	1.500	1.375	1.130	3.750	.500	3.000	2.375	500	3/8-16 X 1-1/4	235.95
SL-500	5.0000	1.250	2.0000	1.375	1.630	4.250	.625	3.750	2.875	.500	1/2-13 X 1-1/2	292.75
SL-600	6.0000	1.500	2.500	1.375	1.630	4.250	.625	4.750	2.875	.500	1/2-13 X 1-3/4	383.35

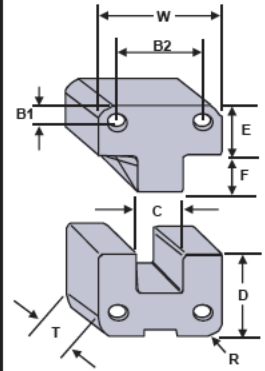

*UPON AVAILABILITY

TAPERED INTERLOCKS (ROUND)



MATERIAL: D2

HARDNESS: 58-62 RC

FEMALE					MALE							
CATALOG NUMBER	PRICE	O.D. +.0000" -.0005"	I.D.	M +.015" -.020"	TAP SIZE	CATALOG NUMBER	PRICE	O.D. +.0000" -.0005"	I.D.	L	M +.015" -.000"	TAP SIZE
TIF-051	21.99	.5000	.312	.875	10-24	TIM-051	20.66	.5000	.312	312	.875	10-24
TIF-052	22.35			1.187		TIM-052	20.99				1.187	
TIF-053	22.55			1.375		TIM-053	21.15				1.375	
TIF-071	22.18	.7500	.500	.875	1/4-20	TIM-071	20.80	.7500	.500	281	.875	1/4-20
TIF-072	22.29			1.187		TIM-072	20.90				1.187	
TIF-073	22.37			1.375		TIM-073	21.00				1.375	
TIF-101	23.32	1.0000	.625	.875	1/4-20	TIM-101	22.05	1.0000	.625	343	.875	1/4-20
TIF-102	23.47			1.187		TIM-102	22.25				1.187	
TIF-103	23.70			1.375		TIM-103	22.40				1.375	
TIF-150	29.88	1.5000	1.000	1.125	5/16-18	TIM-150	28.50	1.5000	1.000	500	1.125	5/16-18
TIF-151	30.30			1.375		TIM-151	28.88				1.375	
TIF-152	30.75			1.625		TIM-152	29.31				1.625	

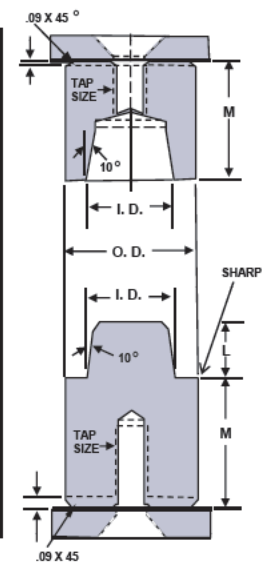

*UPON AVAILABILITY

WORKSHEET MASTER COPY

Special Punches and Perforators

Core Pins

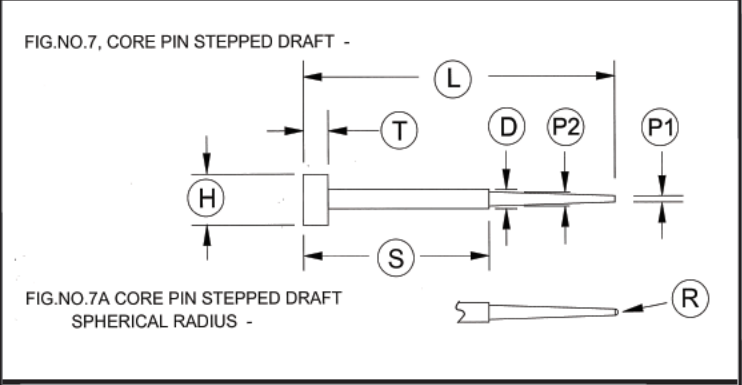
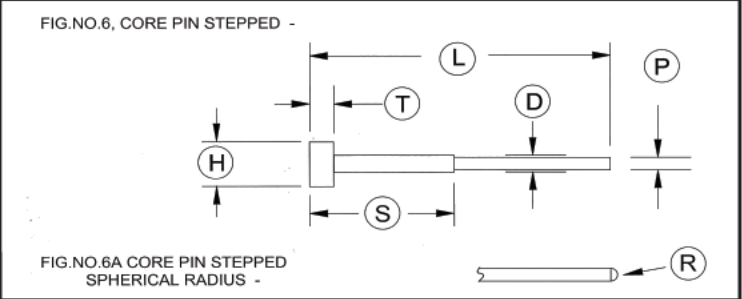
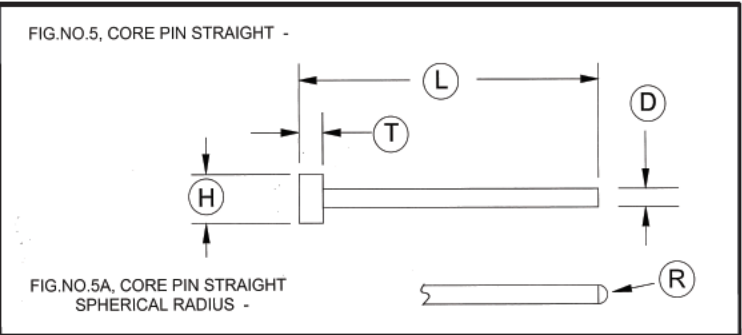
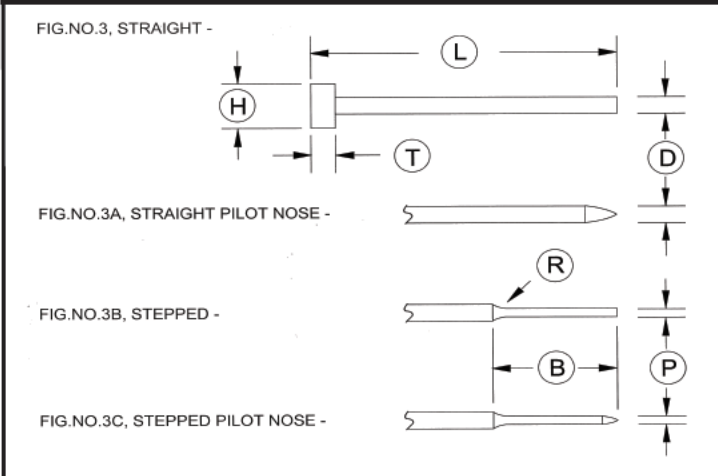
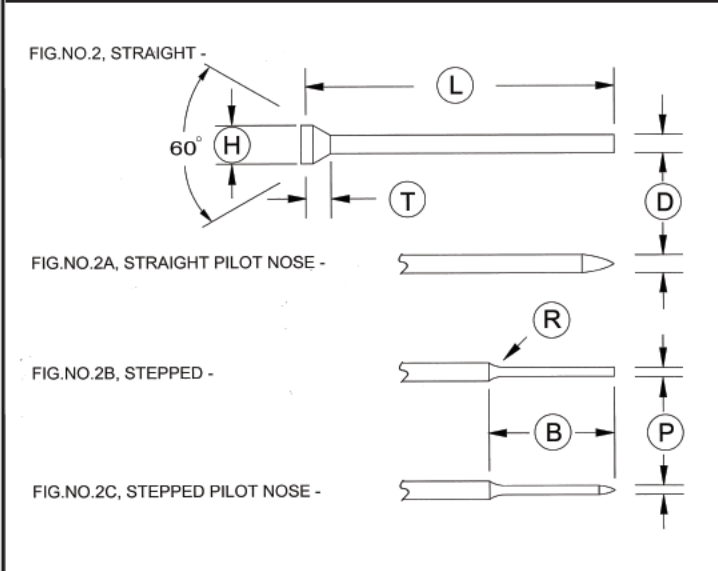
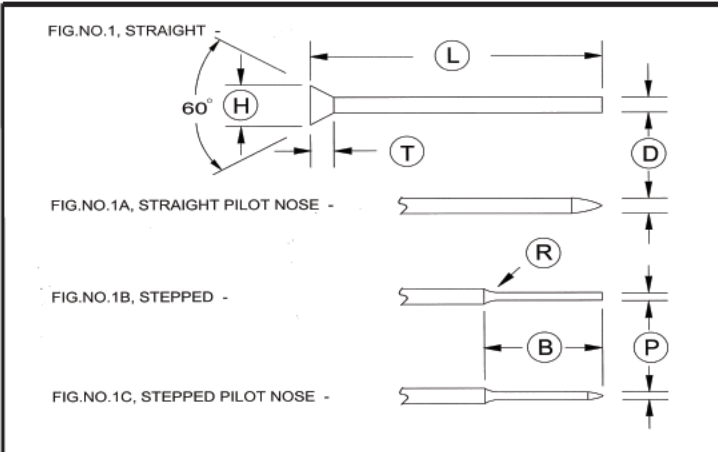

Please specify required tolerances on all dimensions

FIG. _____ QTY. _____

MATL. _____ HARD/ RC _____

Modify Sandard Catalog No. _____

COMMENTS: _____

DIM.	SIZE	TOL.	DIM.	SIZE	TOL.
D			P		
H			P1		
T			P2		
L			B		
S			R		

Company Name _____
 Address _____
 City, State, Zip _____
 Phone _____ Fax _____
 Contact _____
 E-Mail Address _____
 Reference: Request for Quote No. _____

YOUR LOCAL DISTRIBUTOR.

SALES REPRESENTATIVE

Smith Enterprises
 Email: bowcarz@smithpins.com
 Phone: 630-595-0202
 Fax: 630-595-1414

ROYAL DISTRIBUTORSHIP

Here at ROYAL we pride ourselves on being associated with well informed and knowledgeable distributors. It has become a ROYAL tradition to sell our line of products through local distributorships who stock large supplies of ROYAL pins. By doing this, a ROYAL distributor can quickly fill your molding or stamping product needs.

If you are interested in becoming a ROYAL distributor, or if you are a ROYAL customer and would like one of your vendors to become a stocking ROYAL distributor, PLEASE CALL US at 401-245-6900. We can help! Most of our existing distributors were referred to us by satisfied customers of ROYAL DIVERSIFIED PRODUCTS!

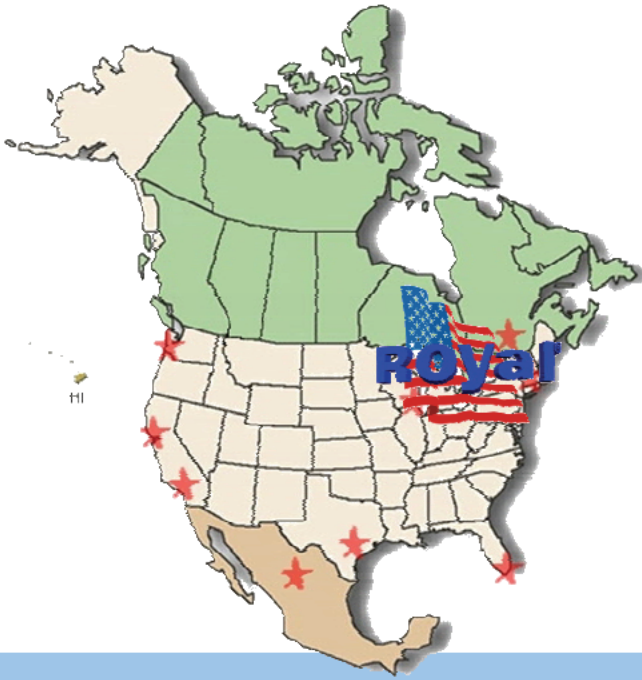

TERMS: Net 30 days. 1-1/2% monthly late charge

Prices: Subject to change without notice.

Minimum Billing: \$35 (Excluding Shipping costs)

Shipments: F.O.B. Shipping Point. Unless otherwise instructed by customer, shipping will be via UPS or the least expensive carrier. We cannot assume charges or responsibility due to transportation difficulties.

Please Note* We use the finest materials in the manufacture of our products. Our steels are DFARS and REACH compliant.

Quotations: Valid for 90 days only, except by special arrangement. We reserve the right to advise the customer of any change in price upon receipt of order. Quotes for premium and expedited parts are valid for 48 hours.

Confirmation/acknowledgements

Standard Catalog Products: Since most orders for catalog standard products are shipped before receipt of a faxed confirmation, ROYAL's policy on telephone orders is a verbal "read back" by our customer service representative.

Non-Standard Products: Orders containing non-standard products are acknowledged via fax within 24 hours from the time it is entered into our system. It is the customers responsibility to check the acknowledgement for correctness of billing and shipping address, terms, shipping instructions, order quantities, size and description and pricing of item(s) ordered.

The customer is to report any discrepancies immediately.

Otherwise ROYAL will assume order to be correct as acknowledged and will proceed accordingly.

Cancellations: Cancellations on Standard items will be subject to a charge of \$10 plus any applicable material and labor costs for work in progress. We do not ship partially finished goods on cancelled orders. Non-standard items and premium services are non cancellable or changeable.

Part numbers: We are not responsible for converting from other manufacturers part numbers/nomenclature. It is the responsibility of the customer to assure that the part quoted/ordered, matches their requirement.

Returns: Prior approval must be obtained within 10 days of shipment receipt date for all returns. When permission is granted, there is 15% re-stocking charge with a 10 dollar minimum. Return shipping is the customer's responsibility. If the return proves to be the fault of ROYAL, the return shipping cost will be credited back to the customer. **Unless** there is a manufacturing discrepancy, specials are not returnable.

The following are not standard stock items and are not returnable:

- ☛ RQA TYPE PINS, 4" LENGTH AND OVER
- ☛ RQB TYPE PINS, 3" LENGTH AND OVER OR WITH "OPTIONAL T" HD. THK. OF 3/16"
- ☛ AB STYLE PINS
- ☛ MQA and MQB TYPE PINS
- ☛ MPB TYPE PINS
- ☛ BH SERIES PINS - 4" AND 6" LENGTHS, ALL DECIMAL DIAS.
- ☛ PTD TYPE PINS
- ☛ MPT TYPE PINS
- ☛ ANY PRODUCTS WITH CUSTOM MODIFICATIONS
- ☛ ANY PIN WITH 4 PLACE DECIMAL DIAMETER
- ☛ ANY PRODUCT SUPPLIED IN LARGER QUANTITIES THAN NORMALLY STOCKED

OVER/UNDER SHIPMENTS: Royal reserves the right to over ship or under ship up to 10% of non-standard products. If an exact quantity is desired "DO NOT OVER OR UNDER SHIP" must be specified **when the quotation is requested.**

Warranty: Royal proudly guarantees that all of our products will conform to your requested physical specifications.

IT IS AGREED BY THE BUYER IN PURCHASING MATERIAL HEREUNDER THAT THE LIABILITY OF ROYAL SHALL BE LIMITED SOLELY TO THE REPAIR OR REPLACEMENT OF THE MATERIAL SOLD. ROYAL SHALL NOT OTHERWISE INCUR LIABILITY FOR ANY DIRECT, SPECIAL OR CONSEQUENTIAL DAMAGES OR EXPENSES.



Whether it's one of our many thousands of standard parts in stock,
or an intricate, high-precision special pin,
ROYAL DIVERSIFIED PRODUCTS
has a precision crafted and economical solution to *any* of your pin requirements.



Smith Enterprises
Email: bowcarz@smithpins.com
Phone: 630-595-0202
Fax: 630-595-1414

